

MODEL 4WI

100 - 800 HP
Steam and Hot Water
Wet-back Integral Burner



CONTENTS

GENERAL.....	A2-3
FEATURES AND BENEFITS	A2-4
Promethean Boilers	A2-4
DIMENSIONS AND RATINGS	A2-5
PERFORMANCE DATA	A2-13
Specifying Boiler Efficiency.....	A2-13
Efficiency Specification	A2-13
Emissions.....	A2-14
ENGINEERING DATA.....	A2-19
Sound Level.....	A2-19
Gas-Fired Burners	A2-19
Oil-Fired Burners	A2-20
General Boiler Information.....	A2-25
Boiler Room Information	A2-25
Stack Support Capabilities.....	A2-25
Stack/Breeching Size Criteria.....	A2-25
Boiler Room Combustion Air	A2-25
SAMPLE SPECIFICATIONS - MODEL 4WI STEAM BOILERS	A2-31
SAMPLE SPECIFICATIONS - MODEL 4WI HOT WATER BOILERS	A2-43

ILLUSTRATIONS

Figure A2-1. Model 4WI Steam Boiler 100-800 HP A2-6
 Figure A2-2. Model 4WI Hot Water Boiler 100-800 HP A2-8
 Figure A2-3. Predicted Stack Temperature Increase for Pressure Greater Than 125 psig - Model 4WI A2-15
 Figure A2-4. Typical Gas Piping Layout A2-21
 Figure A2-5. No. 2 Oil Piping, Single Boiler Installation, Remote Oil Pump A2-23
 Figure A2-6. No. 2 Oil Piping, Multiple Boiler Installation, Remote Oil Pumps A2-23
 Figure A2-7. No. 2 Oil Piping, Multiple Boiler Installation A2-24
 Figure A2-8. No. 2 Oil Transfer Tank Detail (For consideration with elevated boiler rooms) A2-24
 Figure A2-9. Typical Fuel Storage Tank Arrangement A2-25
 Figure A2-10. Boiler Room Length (Typical Layouts) A2-29
 Figure A2-11. Boiler Room Width (Typical Layout) A2-29
 Figure A2-12. Breeching Arrangement A2-30

TABLES

Table A2-1. Horsepower vs Shell Diameter A2-3
 Table A2-2. Model 4WI Steam Boiler Ratings 100 to 800 HP A2-6
 Table A2-3. Model 4WI Steam Boiler Dimensions A2-7
 Table A2-4. Model 4WI Hot Water Boiler Ratings A2-8
 Table A2-5. 4WI Hot Water Boiler Dimensions A2-9
 Table A2-6. Steam Boiler Safety Valve Openings A2-10
 Table A2-7. Hot Water Boiler Safety Valve Openings A2-10
 Table A2-8. Space Required to Open Rear Head on Promethean Boilers Equipped with Davits (4WI) A2-11
 Table A2-9. Boiler Mounting Piers A2-11
 Table A2-10. Lifting Lug Locations A2-12
 Table A2-11. Firing Rates 4WI Boilers with Integral Burner A2-14
 Table A2-12. Predicted Fuel-to-Steam Efficiencies - Natural Gas - Model 4WI A2-15
 Table A2-13. Predicted Fuel-to-Steam Efficiencies - No. 2 Oil - Model 4WI A2-16
 Table A2-14. Promethean Boilers - Natural Gas, Emission Levels - Model 4WI A2-16
 Table A2-15. Promethean Boilers - No. 2 Oil, Emission Levels - Model 4WI A2-16
 Table A2-16. 4WI Gas Pressure at Entrance to Standard, Undersized, and Oversized Gas Trains A2-16
 Table A2-17. Recommended NTI Gas Train Sizes and Pressure Ranges A2-18
 Table A2-18. Predicted Sound Levels (30 ppm NOx system) at High Fire - Model 4WI A2-18
 Table A2-19. Minimum Required Gas Pressure Altitude Conversion A2-20
 Table A2-20. Maximum Gas Consumption (CFH) for Natural Gas and Propane Vapor A2-20
 Table A2-21. Standard Gas Train Connection Size and Location A2-20
 Table A2-22. Gas Train Components A2-22
 Table A2-23. No. 2 Oil Connection Size, Location and Recommended Line Sizes A2-22
 Table A2-24. Blowdown Tank Sizing Information A2-26
 Table A2-25. Heating Surface A2-27
 Table A2-26. Steam Volume Disengaging Area A2-27
 Table A2-27. Recommended Steam Nozzle Size (To Maintain 4000 to 5000 fpm Nozzle Velocity) A2-28
 Table A2-28. Recommended Non-Return Valve Size A2-28
 Table A2-29. Blower Motor Selection 4WI NTI Boilers A2-28
 Table A2-30. Turndown Guarantee 4WI NTI Boilers - Natural Gas & #2 Oil A2-28

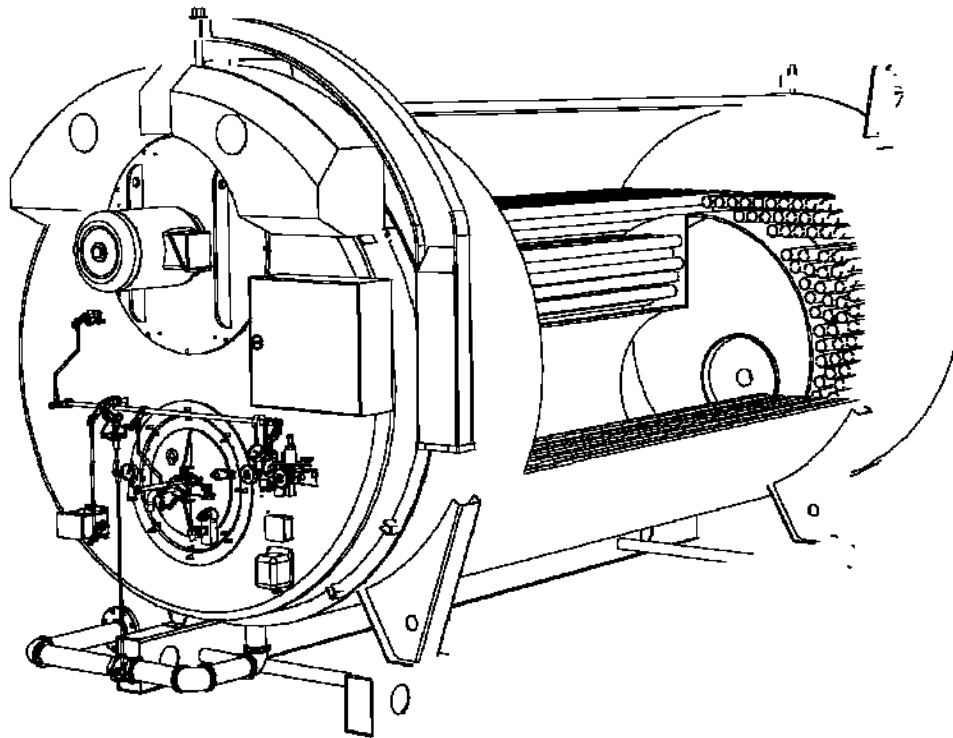

Table A2-1. Horsepower vs Shell Diameter

Wet-Back Boilers	
HP	Dia. (IN)
4WI 100-125	60
4WI 150-200	67
4WI 250-300	78
4WI 350-400	85
4WI 500-600	96
4WI 700-800	106

GENERAL

The Promethean Boiler Model 4WI (100 - 800 hp), provides NOx control, top performance, and reliable Cleaver-Brooks efficiency. The Low Emission capabilities combines the packaging of induced flue gas recirculation with the Cleaver-Brooks integral front head and the Nat-Com burner internal components to gain the ultra-low NOx of 15 to <9 ppm levels on natural gas demanded by the environmental concerns of today. The burner head combines advanced burner technology to match the geometric and aerodynamic parameters to meet the stringent NOx and CO standards for all applications. The front head routes a portion of the flue gases from the fourth pass to the fan and burner assembly for reliable low NOx performance. The enhanced burner design

assures maximum NOx reduction at all firing rates while maintaining top of the line boiler performance.

Low Emission Options include packages from 60 ppm to ultra-low < 9 ppm. (all NOx emission levels are given for natural gas and on a dry volume basis and corrected to 3% O₂):

- Fan diameters and motor horsepower will vary in size depending on NOx reduction requirements with the lower NOx levels requiring larger fans and more horsepower.

Cleaver-Brooks' commitment to lowering emissions is based on more than 2000 low NOx installations - all passing guaranteed emission performance levels.

FEATURES AND BENEFITS

The Cleaver-Brooks Promethean Firetube Boiler model 4WI, is a 4 pass wet-back design including five square feet of heating surface per boiler horsepower, and maximum guaranteed efficiencies. The shell sizes can be found in Table A2-1.

The Promethean model 4WI includes a complete package; pressure vessel, integral burner and controls including the revolutionary Level Master water level control on High pressure steam units. Additionally, options can be added to further enhance the package...

One such option is the CB Hawk ICS, integrated control system providing boiler control, monitoring, communication and system integration in a single PLC based package. To this system you may also add a VSD (variable speed drive) for controlling combustion air, parallel positioning for independent control of fuel and air, modulating feed water valve, and Oxygen trim for additional energy savings in an integrated package.

Promethean Boilers

The Promethean model 4WI is offered with;

- 4-pass wetback design
- 100-800 boiler horsepower, steam or hot water
- Compact footprint; optimized shell and furnace geometry
- Lower furnace heat release
- Integral burner
- Low emissions on natural gas; selections from 60 to Ultra-low NOx reduction (ULNOx(tm)) of 15 - <9 PPM
- Low emissions on #2 oil; 70 PPM with 0.015% fuel bound nitrogen.
- Level Master water level control on high pressure steam units
- Multiple fuel firing
- CB 780E burner management control
- UL/ULC approved package.
- Single point positioning of fuel and air ensures ease of startup and reliable operation.

DIMENSIONS AND RATINGS

The 4 pass Wet-Back boiler ratings for the steam boiler are on Table A2-2 and the 4 pass Wet-Back hot water boilers ratings are on Table A2-4. Dimensions and weights for the 4 pass Wet-Back steam boiler is on Table A2-3. The 4 pass Wet-Back hot water boiler dimension and weights are on Table A2-5.

Notes

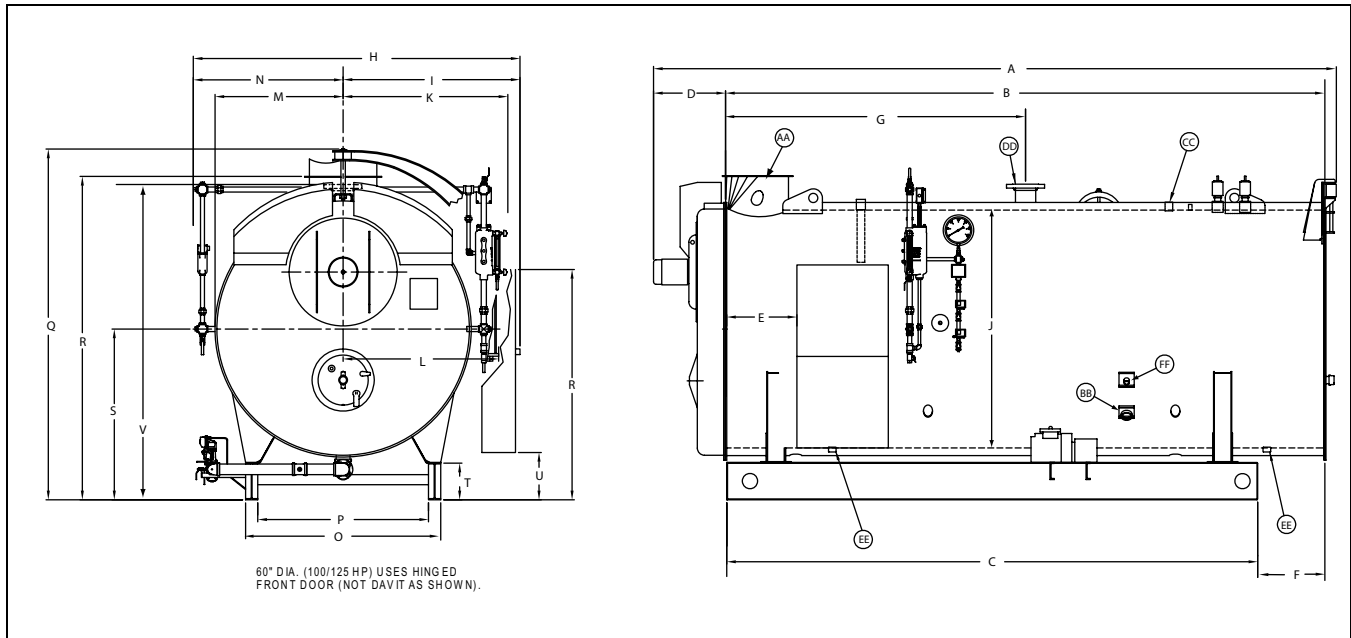

Figure A2-1. Model 4WI Steam Boiler 100-800 HP

Table A2-2. Model 4WI Steam Boiler Ratings 100 to 800 HP

BOILER H.P.	100	125	150	200	250	300	350	400	500	600	700	800
RATINGS - SEA LEVEL TO 700 FT.												
Rated Capacity (lbs-steam/hr from and at 212°F)	3450	4313	5175	6900	8625	10350	12075	13800	17250	20700	24150	27600
Btu Output (1000 Btu/hr)	3347	4184	5021	6694	8368	10042	11715	13389	16736	20083	23430	26778
APPROXIMATE FUEL CONSUMPTION AT RATED CAPACITY BASED ON NOMINAL 82% EFFICIENCY												
Light Oil gph (140,000 Btu/gal)	29.2	36.4	43.7	58.3	72.9	87.5	102.0	116.6	145.8	174.9	204.1	233.3
Gas CFH (1000 Btu)	4082	5102	6123	8164	10205	12246	14287	16328	20410	24492	28574	32656
Gas (Therm/hr)	40.8	51.0	61.2	81.6	102.0	122.5	142.9	163.3	204.1	244.9	285.7	326.6
POWER REQUIREMENTS - SEA LEVEL TO 700 FT. (60 HZ)												
Blower Motor hp (60 ppm) (See Note "A")	2	5	5	7-1/2	10	15	15	20	15	25	30	50
Blower Motor hp (30 ppm) (See Note "A")	3	7-1/2	7-1/2	15	15	20	20	25	30	40	50	75
"Oil Pump Motor, No. 2 Oil"	1/2	1/2	1/2	1/2	1/2	3/4	3/4	3/4	3/4	3/4	1	1
Air Compressor Motor hp (No. 2 Oil firing Only)	3	3	3	3	5	5	5	5	7-1/2	7-1/2	7-1/2	7-1/2
BOILER DATA												
Heating Surface sq-ft. (Fireside)	500	625	750	1000	1250	1500	1750	2000	2500	3000	3500	See Note "B"

NOTE:

- A. Blower motor size for boiler operating pressures 125 psig and less, contact your local Cleaver-Brooks authorized representative for higher pressures and altitude.
- B. 800 hp boilers are available w/ 3500 or 4000 sq. ft. of heating surface

Table A2-3. Model 4WI Steam Boiler Dimensions

BOILER H.P.	DIM	100	125	150	200	250	300	350	400	500	600	700/800	*800
LENGTHS													See Note "C"
Overall Length (60 PPM system)	A	161.63	185.63	175	208	200	220.13	223.5	238.75	245.75	282.75	270.75	297.75
Overall Length (30 PPM system)	A	161.63	185.63	175	208	200	220.13	223.5	247	253.5	287.25	276.75	303.75
Shell	B	131	155	143	176.5	172.3	196.1	189.75	207.75	213.75	248.75	232.75	259.75
Base Frame	C	110	134.13	122	156	150.1	174.1	167.25	185.25	188.25	223.25	207.25	234.25
Front Head Extension (60 PPM system)	D	27	27	28	27.63	28	30	34.25	27	28	34	34	34
Front Head Extension (30 PPM system)	D	27	27	28	27.63	28	30	34.25	35.25	36.75	38.5	38.5/40.5	40.5
Shell Ring Flange to Panel	E	17	17	17	17	17	23	23	26	26	26	26	26
Rear Ring Flange to Base	F	20.5	20.5	20.63	20.5	22	22	22.5	22	25	25	25	25
Shell Flange to Steam Nozzle 15 psi	G	78.38	88.38	87.38	93.38	84.38	98.38	94.5	104.5	101.5	124.5	110.5	128.5
Shell Flange to Steam Nozzle 150 psi	G	70.38	90.38	73.38	87.38	92.38	98.38	95.5	104.5	106.5	124.5	115.5	128.5
WIDTHS													
Overall Width	H	90.25	90.25	94.38	94.38	107	107	114	114	124.75	124.75	134.68	134.68
Center to Panel	II	48.5	48.5	52	52	58	58	61.5	61.5	67	67	72	72
I.D. Boiler	J	60	60	67	67	78	78	85	85	96	96	106	106
Center to Water Column	K	44.38	44.38	48.5	48.5	54	54	57.5	57.5	63	63	68	68
Center to Outside Davit/Hinge	L	35	35	41.5	41.5	51	51	58	56.5	62	64.65	67	67
Center to Lagging	M	32.5	32.5	36.75	36.75	42	42	45	45	50.46	50.46	56	56
Center to Auxiliary LWCO	N	38.75	38.75	42.38	43.38	49	49	52	52	59	57.68	62.68	62.68
Base Outside	O	52.5	52.5	51	51	64	64	60	60	71.88	71.88	74.75	74.75
Base Inside	P	44.5	44.5	43	43	56	56	47	47	58.88	58.88	61.75	61.75
HEIGHTS													
Overall Height	Q	86	86	101.75	101.75	115	115	123.5	123.5	134	134	145.5	145.5
Base to Vent Outlet	R	85	85	92.63	92.63	106	106	115	115	126	126	135.63	135.63
Base to Boiler Centerline	S	46	46	50	50	56	56	61	61	67	67	71	71
Height of Base Frame	T	12	12	12	12	12	12	12	12	12	12	12.25	12.25
Base to Bottom of Panel	U	16.5	16.5	14.75	14.75	15.5	15.5	17	17	16.5	16.5	16.75	16.75
Base to Steam Nozzle	V	82.38	82	89.88	89.88	101.5	103.5	110	109.5	121	122	130.5	130.5
BOILER CONNECTIONS													
Feedwater Inlet (Both Sides)	BB	1.25	1.5	1.5	2	2	2	2.5	2.5	2.5	2.5	2.5	2.5
Surface Blowoff (150 lb only)	CC	1	1	1	1	1	1	1	1	1	1	1	1
Steam Nozzle 15 lb (See Note "A")	DD	8	8	8	10	10	12	12	12	12	12	12	12
Steam Nozzle 150 lb (See Note "B")	DD	4	4	4	4	6	6	6	6	8	8	8	8
Blowdown-Front & Rear (15 lb)	EE	1.5	1.5	1.5	2	2	2	2	2	2	2	2	2
Blowdown-Front & Rear (150 lb)	EE	1.25	1.5	1.5	1.5	1.5	1.5	1.5	2	2	2	2	2
Chemical Feed	FF	1	1	1	1	1	1	1	1	1	1	1	1
VENT STACK													
Vent Stack Diameter (Flanged)	AA	16	16	16	16	20	20	24	24	24	24	24	24
MINIMUM CLEARANCES													
Rear Door Swing		36	36	40	40	46	46	50	50	55	55	60	60
Front Door Swing		67	67	78	78	89	89	97	97	108	108	118	118
Tube Removal - Front Only		96	120	108	142	132.5	156.5	148	166	169	204	188	215
MINIMUM BOILER ROOM LENGTH ALLOWING FOR DOOR SWING AND TUBE REMOVAL FROM:													
Thru Window or Door		234	258	261	295	308	332	337	355	377	412	411	438
Front of Boiler		263	311	291	359	351	399	388	424	438	508	481	535
WEIGHTS IN LBS													
Normal Water Weight	-	5,870	7,310	7,625	10,000	12,590	14,848	16,025	17,960	21,055	25,355	28,700	32,770
Approx. Shipping Weight - (15psig)	-	11,760	12,980	14,200	16,260	20,130	22,080	25,810	27,950	33,810	38,170	41,980	46,300
Approx. Shipping Weight - (150psig)	-	12,500	13,900	15,200	17,700	22,640	24,200	28,000	30,400	36,700	39,580	45,940	50,480

NOTES:

Accompanying dimensions, while sufficiently accurate for layout purposes, must be confirmed for construction by certified dimension diagram/drawing. All Connections are Threaded Unless Otherwise Indicated:

NOTE "A": ANSI 150 psig Flange

NOTE "B": ANSI 300 psig Flange

NOTE "C": *800 hp w/ 4000 sq. ft. of heating surface



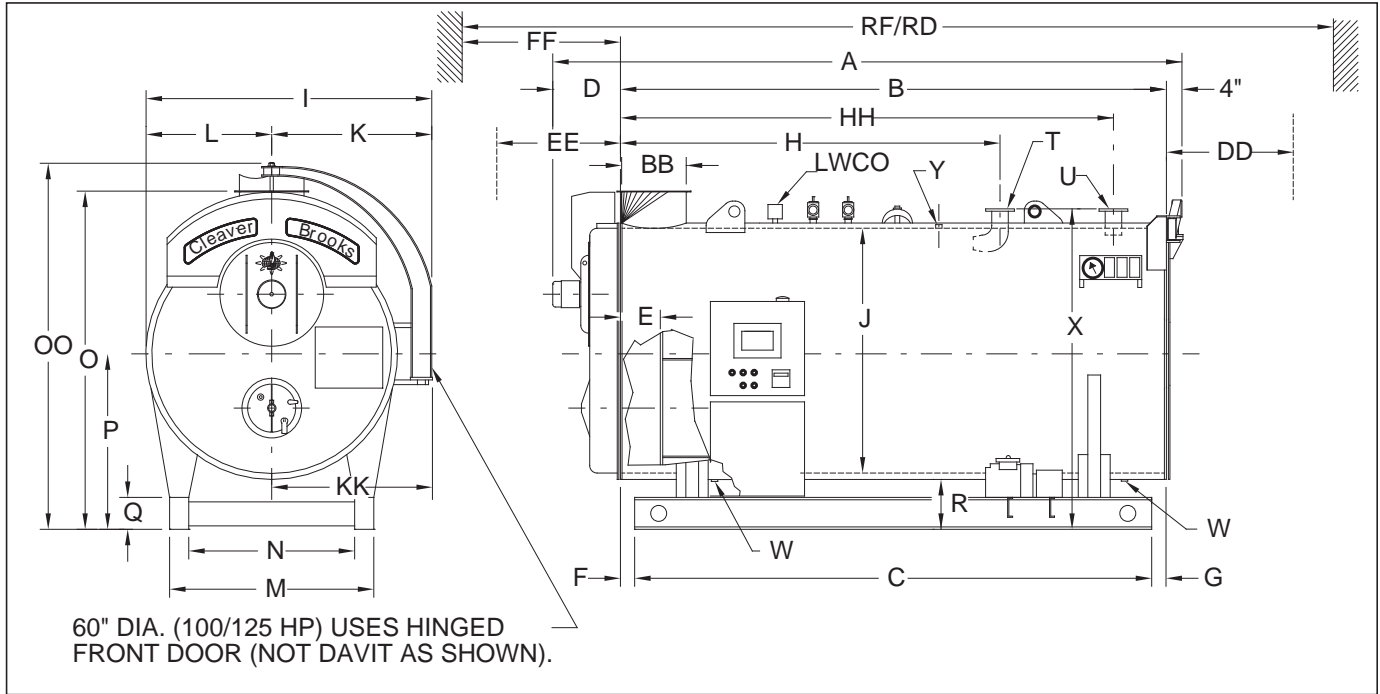

Figure A2-2. Model 4WI Hot Water Boiler 100-800HP

Table A2-4. Model 4WI Hot Water Boiler Ratings

BOILER H.P.	100	125	150	200	250	300	350	400	500	600	700	800
RATINGS - SEA LEVEL TO 700 FT.												
Btu Output (1000 Btu/hr)	3347	4184	5021	6694	8368	10042	11715	13389	16736	20083	23430	26778
APPROXIMATE FUEL CONSUMPTION AT RATED CAPACITY BASED ON NOMINAL 82% EFFICIENCY												
Light Oil gph (140,000 Btu/gal)	29.2	36.4	43.7	58.3	72.9	87.5	102.0	116.6	145.8	174.9	204.1	233.3
Gas CFH (1000 Btu)	4082	5102	6123	8164	10205	12246	14287	16328	20410	24492	28574	32656
Gas (Therm/hr)	40.8	51.0	61.2	81.6	102.0	122.5	142.9	163.3	204.1	244.9	285.7	326.6
POWER REQUIREMENTS - SEA LEVEL TO 700 FT. (60 HZ)												
Blower Motor hp (60 ppm)	2	5	5	7-1/2	10	15	15	20	15	25	30	50
Blower Motor hp (30 ppm)	3	7-1/2	7-1/2	15	15	20	20	25	30	40	50	75
Oil Pump Motor, No. 2 Oil	1/2	1/2	1/2	1/2	1/2	3/4	3/4	3/4	3/4	3/4	1	1
Air Compressor Motor hp (No. 2 Oil firing Only)	3	3	3	3	5	5	5	5	7-1/2	7-1/2	7-1/2	7-1/2
BOILER DATA												
Heating Surface sq.-ft. (Fireside)	500	625	750	1000	1250	1500	1750	2000	2500	3000	3500	See Note "A"

NOTE 'A': 800 hp boilers are available w/ 3500 or 4000 sq. ft. of heating surface

Table A2-5. 4WI Hot Water Boiler Dimensions

BOILER H.P.	DIM	100	125	150	200	250	300	350	400	500	600	700/800	*800
LENGTHS													See Note "C"
Overall Length (60 PPM system)	A	162	186	175	209	200	225.5	221.75	238.75	245.75	282.75	270.75	297.75
Overall Length (30 PPM system)	A	162	186	175	209	200	225.5	221.75	247	253.5	287.25	276.75	303.75
Shell	B	131	155	143	177	172.5	196.5	189.75	207.75	213.75	248.75	232.75	259.75
Base Frame	C	110	124	122	156	150.12	174.12	167.25	185.25	188.25	223.25	207.25	207.25
Front Head Extension (60 PPM)	D	27	27	28	28	23.5	25	28	27	28	30	34	34
Front Head Extension (30 PPM)	D	27	27	28	28	23.5	25	28	35.25	35.75	34.5	40	40
Shell Extension	E	12	12	12	12	14.5	14.5	16.75	16.75	16.25	16.25	16.75	16.75
Shell Ring Flange to Base	F	0.5	0.5	0.5	0.5	0.5	0.5	0.5	0.5	0.5	0.5	0.5	0.5
Rear Ring Flange to Base	G	20.5	20.5	20.5	20.5	22	22	22	22	25	25	25	25
Shell Flange to Return	H	78	99	87	121	113.5	137.5	130.75	148.75	143	151.75	146.75	173.75
Shell Flange to Outlet	HH	103	124	112	146	139.5	163.5	156.75	174.75	179	187.75	182.75	209.75
WIDTHS													
Overall Width	I	75.5	75.5	82.75	82.75	93	93	102	102	113	113	123	123
I.D. Boiler	J	60	60	67	67	78	78	85	85	96	96	106	106
Center to Entrance Box	K	42.5	42.5	46	46	51	51	56.5	56.5	62	62	67	67
Center to Outside Davit/Hinge	KK	35	35	41.5	41.5	51	51	56.5	56.5	62	62	67	67
Center to Lagging	L	33	33	36.75	36.75	42	42	45.5	45.5	51	51	56	56
Base Outside	M	52.5	52.5	51	51	64	64	60	60	71.88	71.88	74.75	74.75
Base Inside	N	44.5	44.5	43	43	56	56	47	47	58.88	58.88	61.75	61.75
HEIGHTS													
Overall Height	OO	87	87	101.75	101.75	115	115	123.5	123.5	134	134	145.5	145.5
Base to Vent Outlet	O	87	87	92.63	92.63	106	106	115	115	126	126	135.63	135.63
Base to Boiler Centerline	P	46	46	50	50	56	56	61	61	67	67	71	71
Height of Base Frame	Q	12	12	12	12	12	12	12	12	12	12	12	12
Base to Bottom of Boiler	R	15.63	15.63	16.13	16.13	16.5	16.5	18	18	18.5	18.5	17.5	17.5
Base to Return & Outlet	X	82.38	82.38	89.88	89.88	101.5	101.5	110	110	121.5	121.5	130.5	130.5
BOILER CONNECTIONS													
Water Return (See Note "A")	T	4	6	6	6	8	8	8	10	10	12	12	12
Water Outlet (See Notes "A & B")	U	4	6	6	6	8	8	8	10	10	12	12	12
Drain-Front & Rear	W	1.5	1.5	1.5	2	2	2	2	2	2	2	2	2
Air Vent	Y	1.5	1.5	1.5	1.5	1.5	1.5	1.5	2	2	2	2	2
VENT STACK													
Vent Stack Diameter (Flanged)	BB	16	16	16	16	20	20	24	24	24	24	24	24
MINIMUM CLEARANCES													
Rear Door Swing	DD	36	36	40	40	46	46	50	50	55	55	60	60
Front Door Swing	EE	67	67	78	78	89	89	97	97	108	108	118	118
Tube Removal - Front Only	FF	96	120	108	142	132.5	156.5	148	166	169	204	188	215
MINIMUM BOILER ROOM LENGTH													
Thru Window or Door	RD	234	258	261	295	308	332	337	355	377	412	411	438
Front of Boiler	RF	263	311	291	359	351	399	388	424	438	508	481	535
WEIGHTS IN LBS													
Normal Water Weight	-	6,888	8,569	8,857	11,590	14,746	17,368	19,212	21,507	26,251	31,571	35,878	40,930
Approx. Shipping Weight - (30psig)	-	11,760	12,980	14,200	16,260	20,130	22,080	25,810	27,950	33,810	38,170	41,980	45,960
Approx. Shipping Weight - (125psig)	-	12,500	13,870	15,150	17,680	21,690	24,170	27,980	30,370	35,900	40,560	45,090	49,400

NOTES:

Accompanying dimensions, while sufficiently accurate for layout purposes, must be confirmed for construction by certified dimension diagram/drawing.

All Connections are Threaded Unless Otherwise Indicated:

NOTE "A": ANSI 150 psig Flange

NOTE "B": Water Outlet includes 2" Dip Tube

NOTE "C": 800 HP w/ 4000 sq. ft. of heating surface



Table A2-6. Steam Boiler Safety Valve Openings

VALVE SETTING	15 PSIG STEAM		150 PSIG STEAM		200 PSIG STEAM		250 PSIG STEAM		300 PSIG STEAM	
BOILER HP	NO. OF VALVES REQ'D	OUTLET SIZE (IN.)	NO. OF VALVES REQ'D	OUTLET SIZE (IN.)	NO. OF VALVES REQ'D	OUTLET SIZE (IN.)	NO. OF VALVES REQ'D	OUTLET SIZE (IN.)	NO. OF VALVES REQ'D	OUTLET SIZE (IN.)
100	1	2-1/2	1	1-1/2	1	1-1/2	1	1-1/4	1	1-1/4
125	1	3	2	(1) 1-1/2 (1) 1-1/4	2	(1) 1-1/4 (1) 1	2	1	2	1
150	1	3	2	(1) 1-1/2 (1) 1-1/4	2	(1) 1 (1) 1-1/4	2	1	2	1
200	2	2-1/2	2	1-1/2	2	(1) 1-1/2 (1) 1-1/4	2	1-1/4	2	(1) 1 (1) 1-1/4
250	2	(1) 2-1/2 (1) 3	2	(1) 2 (1) 1-1/2	2	1-1/4	2	(1) 1-1/2 (1) 1-1/4	2	1-1/4
300	2	3	2	(1) 2 (1) 1-1/2	2	1-1/2	2	1-1/4	2	(1) 1-1/2 (1) 1-1/4
350	3	(1) 2 (2) 3	2	2	2	(1) 1-1/2 (1) 2	2	1-1/2	2	(1) 1-1/2 (1) 1-1/4
400	3	(2) 3 (1) 2-1/2	2	(1) 2-1/2 (1) 2	2	(1) 1-1/2 (1) 2	2	(1) 1-1/2 (1) 2	2	1-1/2
500	3	3	2	(1) 2-1/2 (1) 2	2	(1) 2-1/2 (1) 2	2	(1) 1-1/2 (1) 2	2	(1) 1-1/2 (1) 2
600	4	(3) 3 (1) 2-1/2	2	2-1/2	2	(1) 2 (1) 2-1/2	2	2	2	2
700	5	(3) 3 (2) 2-1/2	3	(2) 2-1/2 (1) 2	2	2-1/2	2	(1) 2 (1) 2-1/2	2	2
800	5	(3) 3 (2) 2-1/2	3	(2) 2-1/2 (1) 2	2	2-1/2	2	(1) 2 (1) 2-1/2	2	(1) 2 (1) 2-1/2

NOTE: Valve manufacturers are Kunkle, Consolidated or Conbraco, depending on availability. Table revised 04/2012.

Table A2-7. Hot Water Boiler Safety Valve Openings

VALVE SETTING	30 PSIG HW		125 PSIG HW		150 PSIG HTHW	
BOILER HP	NO. OF VALVES REQ'D	OUTLET SIZE (IN.)	NO. OF VALVES REQ'D	OUTLET SIZE (IN.)	NO. OF VALVES REQ'D	OUTLET SIZE (IN.)
100	1	2-1/2	1	1-1/4	1	2
125	1	2-1/2	1	1-1/4	2	(1) 1-1/2 (1) 2
150	1	2-1/2	1	2	2	(1) 1-1/2 (1) 2
200	2	(1) 2-1/2 (1) 1-1/4	1	2	2	2
250	2	(1) 2 (1) 2-1/2	1	2	2	(1) 2 (1) 2-1/2
300	2	2-1/2	1	2-1/2	2	2-1/2
350	3	(2) 2-1/2 (1) 1	1	2-1/2	2	(1) 2-1/2 (1) 3
400	3	(1) 2 (2) 2-1/2	1	2-1/2	2	(1) 2-1/2 (1) 3
500	4	(1) 1 (3) 2-1/2	2	(1) 1 (1) 2-1/2	2	3
600	4	(3) 2-1/2 (1) 2	2	(1) 1-1/4 (1) 2-1/2	3	(2) 3 (1) 2-1/2
700, 800	5	(1) 1 (4) 2-1/2	2	(1) 2-1/2 (1) 2	3	3

NOTE: Relief valve is Kunkle #537 for 30# & 125#(Section IV) boiler and is Kunkle #927 for 150# HTHW(Section I) boiler.

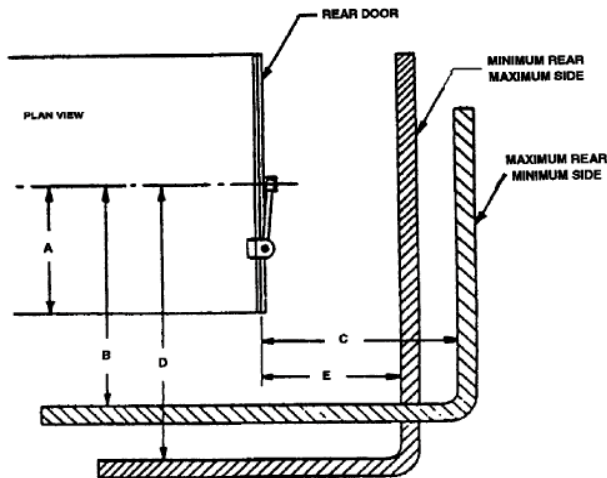

BOILER HP	ALL DIMENSIONS IN INCHES				
HP	A	B	C	D	E
100-125	33	47	52	80	36
150-200	36.5	49	56	83	40
250-300	42	56	61	92	46
350-400	45.5	58	68	99	50
500-600	51	66	75	111	55
700-800	56	74	80	121	60

Table A2-8. Space Required to Open Rear Head on Promethean Boilers Equipped with Davits (4WI)

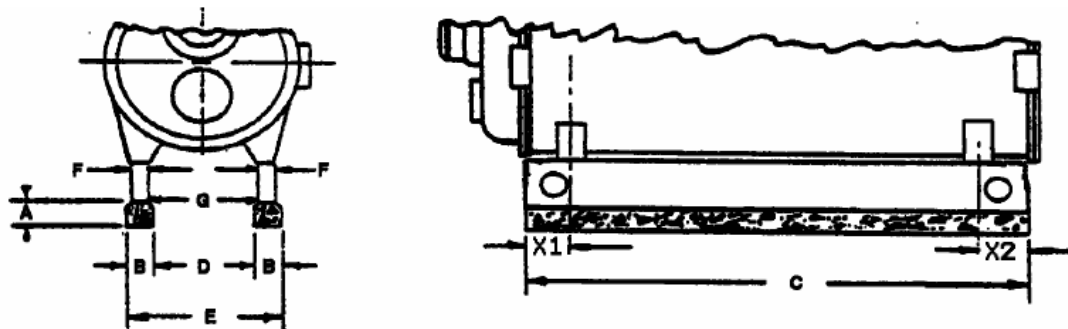

BOILER HP	ALL DIMENSIONS IN INCHES									
	A	B	C	D	E	F	G	X1	X2	
100	6	9	110	39.5	57.5	4	44.5	12	8	
125	6	9	124	39.5	57.5	4	44.5	12	8	
150	6	9	122	38	56	4	43	12	8	
200	6	9	156	38	56	4	43	12	8	
250	6	9	150.125	51	69	4	56	16.125	11.5	
300	6	9	174.125	51	69	4	56	16.125	11.5	
350	6	12	167.25	41.5	65.5	6.5	47	17.75	11.5	
400	6	12	185.25	41.5	65.5	6.5	47	17.75	11.5	
500	6	12	188.25	53.375	77.375	6.5	58.875	18.75	10.5	
600	6	12	223.25	53.375	77.375	6.5	58.875	18.75	10.5	
700-800	6	12	207.25	56.25	80.25	6.5	61.75	18.75	10.5	

NOTE:
6-inch high mounting piers recommended for use beneath the boiler base frame. The use of these piers provides increased inspection accessibility to the boiler and added height for washing down the area beneath the boiler.

Table A2-9. Boiler Mounting Piers

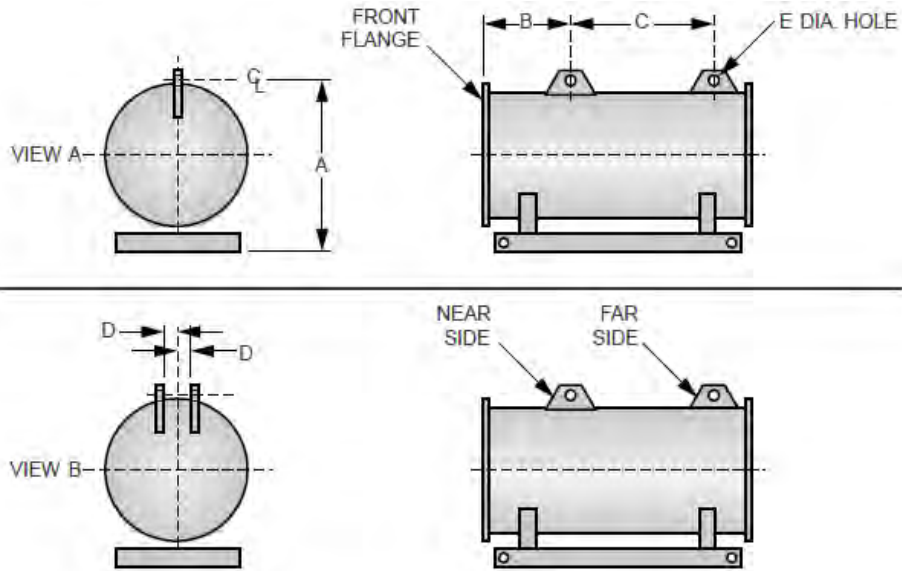

BOILER HP	ALL DIMENSIONS IN INCHES				
	A	B	C	D	E
100	79.5	21.375	84.75	10	3
125	79.5	21.375	108.75	10	3
150	87.125	21.375	96.75	10	3
200	87.125	21.375	130.75	10	3
250	99	28.75	104.25	10	3
300	99	28.75	128.25	10	3
350	107.625	33.25	126	10	3
400	107.625	33.25	144	10	3
500	125.375	34.5	145	10	3
600	125.375	34.5	180	10	3
700-800	134.5	34.5	164	10	3

NOTE: A, B, and C dimensions may vary by 1 inch.

Table A2-10. Lifting Lug Locations

PERFORMANCE DATA

The Low Emission Option provides NO_x reduction at current published and predicted fuel-to-steam efficiencies. Refer to Table A2-12 and Table A2-13.

Specifying Boiler Efficiency

Cleaver-Brooks offers an industry leading fuel-to-steam boiler efficiency guarantee for Promethean 4WI Firetube Boilers. The guarantee is based on the fuel-to-steam efficiencies shown in the efficiency tables and the following conditions. The efficiency percent number is only meaningful if the specific conditions of the efficiency calculations are clearly stated in the specification (see Cleaver-Brooks publication CB-7768 for a detailed description of efficiency calculations).

When specifying the efficiencies in the tables, be sure to include the specific guarantee conditions to maximize the effectiveness of your efficiency specification. If you have any questions regarding the efficiency specifications, please contact your local Cleaver-Brooks authorized representative.

Efficiency Specification

The boiler manufacturer shall guarantee that, at the time of startup, the boiler will achieve fuel-to-steam/water efficiency (as shown in Table A2-12 and Table A2-13) at 100% firing rate (Reference efficiency guarantees at 25%, 50%, and 75% of rating, if required). If the boiler(s) fail to achieve the corresponding guaranteed efficiency as published, the boiler manufacturer will rebate, to the ultimate boiler owner, ten thousand dollars (\$10,000) for every full efficiency point (1.0%) that the actual efficiency is below the guaranteed level.

The specified boiler efficiency is based on the following conditions.

1. Fuel specification used to determine boiler efficiency:

- Natural Gas
 - Carbon,% (wt) = 69.98
 - Hydrogen,% (wt) = 22.31
 - Sulfur,% (wt) = 0.0
 - Heating value, Btu/lb. = 21,830
- No. 2 Oil
 - Carbon,% (wt) = 85.8
 - Hydrogen,% (wt) = 12.7
 - Sulfur,% (wt) = 0.2
 - Heating value, Btu/lb. = 19,420
- No. 6 Oil
 - Carbon,% (wt) = 86.6
 - Hydrogen,% (wt) = 10.9
 - Sulfur,% (wt) = 2.09
 - Heating value, Btu/lb. = 18,830

2. Efficiencies are based on ambient air temperature of 80 °F, relative humidity of 30%, and 15% excess air in the exhaust flue gas.

3. Efficiencies are based on manufacturer's published radiation and convection losses. (For Cleaver-Brooks radiation and convection losses, see Boiler Efficiency Facts Guide, publication number CB-7767).

4. Any efficiency verification testing will be based on the stack loss method.

For efficiencies and stack temperatures at operating pressures not listed, follow these procedures:

When the operating steam pressure is between 10 psig and 125 psig, interpolate the values from the efficiency tables.

When the operating steam pressure is above 125 psig, estimated efficiency can be calculated as follows:

Example:

Boiler: 350 hp.

Fuel: natural gas.

Operating steam pressure: 200 psig.

Find the fuel-to-steam efficiency at 100% firing rate. From Table A2-12 a boiler operating at 100% firing rate and an operating steam pressure of 125 psig, the efficiency is 82.1%.

Using Figure A2-3, note that the stack temperature increases 36 °F at the higher operating pressure. To estimate boiler efficiency, use this rule of thumb: For every 40 °F increase in stack temperature, efficiency decreases by 1%. Since the stack temperature rise is 36 °F, the decrease in the boiler efficiency at 200 psig operating pressure is calculated as follows: $36/40 = .9\%$. Therefore, the boiler efficiency at 200 psig operating pressure is $82.1 - .9 = 81.2\%$

Emissions

The emission data included in this section consists of typical emission levels for the 4WI boiler equipped with 60 & 30 ppm reduction with natural gas or No. 2 oil.

Table A2-11. Firing Rates 4WI Boilers with Integral Burner

BHP	Natural Gas, 1000 Btu/hr		No. 2 Oil, GPH	
	Low	High	Low	High
100	1021	4082	7.3	29.2
125	1276	5103	9.1	36.4
150	1531	6124	10.9	43.7
200	2041	8165	14.6	58.3
250	1021	10206	9.1	72.9
300	1225	12247	10.9	87.5
350	1428	14280	12.8	102.1
400	1633	16329	14.6	116.6
500	2042	20415	18.2	145.8
600	2449	24494	21.9	175
700	2858	28576	25.5	204.1
750	3062	30617	27.3	218.7
800	3266	32659	29.2	233.3

Notes:

Fuel input rates are based on nominal 82% efficiency.

No. 2 Oil = 140,000 Btu/Gal

Table A2-12. Predicted Fuel-to-Steam Efficiencies - Natural Gas - Model 4WI

BHP	OPERATING PRESSURE = 10 psig				OPERATING PRESSURE = 125 psig			
	% OF LOAD				% OF LOAD			
	25%	50%	75%	100%	25%	50%	75%	100%
100	84.4	84.6	84.1	83.6	81.6	82.0	81.7	81.3
125	84.6	85.0	84.7	84.3	81.8	82.3	82.2	82.0
150	84.5	84.8	84.4	83.9	81.6	82.0	81.7	81.3
200	84.7	85.2	85.1	84.8	81.8	82.4	82.3	82.2
250	84.7	85.1	84.9	84.5	81.8	82.4	82.3	82.1
300	84.8	85.3	85.2	85.0	81.9	82.6	82.6	82.5
350	84.7	85.2	85.1	84.8	81.8	82.4	82.3	82.1
400	85.4	85.6	85.5	85.2	82.6	82.9	82.8	82.6
500	85.4	85.6	85.5	85.3	82.6	83.0	82.9	82.8
600	85.5	85.8	85.7	85.6	82.7	83.2	83.2	83.1
700	85.5	85.7	85.7	85.6	82.7	83.1	83.1	83.0
800	85.5	85.8	85.7	85.6	82.7	83.1	83.1	83.0

Note: Using the ultra low NOx burner (15-<9ppm) will result in a slight reduction of fuel-to-steam efficiency.

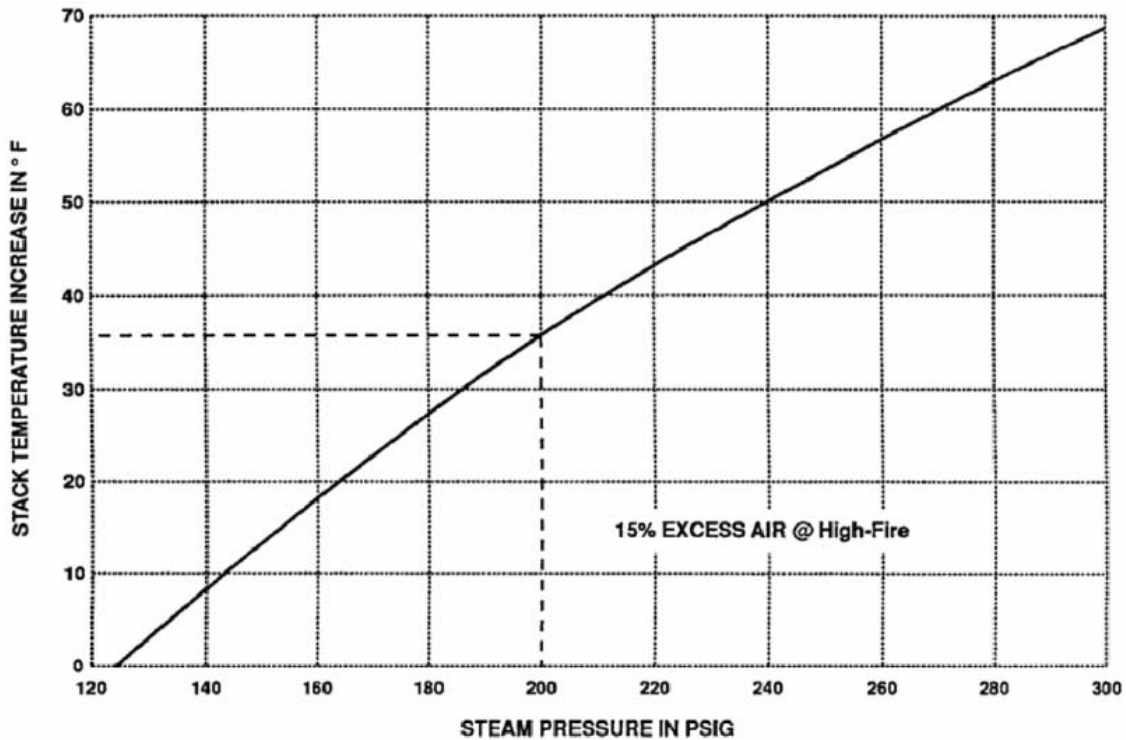

Figure A2-3. Predicted Stack Temperature Increase for Pressure Greater Than 125 psig - Model 4WI

Table A2-13. Predicted Fuel-to-Steam Efficiencies - No. 2 Oil - Model 4WI

BHP	OPERATING PRESSURE = 10 psig				OPERATING PRESSURE = 125 psig			
	% OF LOAD				% OF LOAD			
	25%	50%	75%	100%	25%	50%	75%	100%
100	87.9	88.1	87.6	87.0	85.1	85.4 85.1	84.7	
125	88.0	88.5	88.2	87.8	85.2	85.7 85.7	85.5	
150	88.0	88.3	87.9	87.4	85.1	85.4 85.1	84.8	
200	88.2	88.7	88.5	88.2	85.3	85.8 85.7	85.6	
250	88.1	88.6	88.3	88.0	85.3	85.8 85.7	85.6	
300	88.2	88.8	88.6	88.4	85.4	86.0 86.0	86.0	
350	88.2	88.7	88.5	88.2	85.3	85.8 85.7	85.6	
400	88.8	89.0	88.9	88.7	86.0	86.3 86.2	86.0	
500	88.8	89.0	88.9	88.7	86.1	86.4 86.4	86.2	
600	88.9	89.2	89.2	89.1	86.2	86.6 86.6	86.6	
700	88.9	89.2	89.1	89.0	86.1	86.5 86.5	86.4	
800	88.9	89.2	89.2	89.1	86.1	86.5 86.5	86.4	

Note: Using the ultra low NOx burner (15-<9ppm) will result in a slight reduction of fuel-to-steam efficiency.

Table A2-14. Promethean Boilers - Natural Gas, Emission Levels - Model 4WI

POLLUTANT	UNITS	60 PPM SYSTEM	30 PPM SYSTEM
CO	ppm*	50/150**	50/150**
	lb/MMbtu	0.04/0.11	0.04/0.11
NOx	ppm*	60	30
	lb/MMbtu	0.07	0.035
SOx	ppm*	1	1
	lb/MMbtu	0.001	0.001
HC/VOC ₅	ppm*	10	10
	lb/MMbtu	0.004	0.004
PM	ppm*	-	-
	lb/MMbtu	0.01	0.01

* ppm levels are given on a dry volume basis and are corrected to 3% oxygen (15% excess air)
 ** CO emission is 50 ppm when boiler is operating above 50% of rated capacity. CO emission is 150 ppm when boiler is operating below 50% of rated capacity.

Table A2-15. Promethean Boilers - No. 2 Oil, Emission Levels - Model 4WI

POLLUTANT	UNITS	60 PPM SYSTEM	30 PPM SYSTEM
CO	ppm*	50	50
	lb/MMbtu	0.04	0.04
NOx	ppm*	140	90
	lb/MMbtu	0.186	0.12
SOx	ppm*	278	278
	lb/MMbtu	0.52	0.52
HC/VOC ₅	ppm*	4	4
	lb/MMbtu	0.002	0.002
PM	ppm*	-	-
	lb/MMbtu	0.025	0.025

* ppm levels are given on a dry volume basis and are corrected to 3% oxygen (15% excess air) BASED ON THE FOLLOWING CONSTITUENT LEVELS:
 Fuel-bound Nitrogen content = 0.015% by weight
 Sulfur content = 0.5% by weight
 Ash content = 0.01% by weight

Table A2-16. 4WI Gas Pressure at Entrance to Standard, Undersized, and Oversized Gas Trains

Boiler HP	Pipe Size	30 PPM	60 PPM
		Pressure Range PSI	Pressure Range PSI
100	1.5"	0.6 - 2.0	0.5 - 2.0
125	1.5"	0.8 - 3.0	0.8 - 3.0
150	1.5"	1.0 - 3.0	0.9 - 3.0
200	1.5"	1.7 - 4.0	1.6 - 4.0
	2"	1.1 - 1.7	1.1 - 1.6
250	1.5"	2.4 - 5.0	2.5 - 5.0
	2"	1.5 - 2.4	1.6 - 2.5
300	1.5" - 2"	2.9 - 5.0	3.1 - 5.0
	2"	1.9 - 2.9	2.1 - 3.1
	3"	1.2 - 1.9	1.4 - 3.1
350	1.5" - 2"	3.8 - 5.0	3.8 - 5.0
	2"	2.8 - 3.8	2.8 - 3.8
	2.5"	2.1 - 2.8	2.1 - 2.8
	3"	1.4 - 2.1	1.4 - 2.1
400	1.5" - 2"	5.0 - 7.0	5.0 - 7.0
	2"	3.5 - 5.0	3.5 - 5.0
	2.5"	2.7 - 3.5	2.7 - 3.5
	3"	1.8 - 2.7	1.9 - 2.7
500	1.5" - 2.5"	6.6 - 10.0	6.6 - 10.0
	2" - 2.5"	4.7 - 6.6	4.7 - 6.6
	2.5"	3.3 - 4.7	3.3 - 4.7
	3"	1.9 - 3.3	1.9 - 3.3
600	1.5" - 2.5"	9.5 - 10.0	9.5 - 10.0
	2" - 2.5"	6.8 - 9.5	6.8 - 9.5
	2.5"	4.8 - 6.8	4.8 - 6.8
	2.5" - 3"	4.1 - 4.8	4.1 - 4.8
	3"	2.8 - 4.1	2.7 - 4.1
700	2" - 3"	8.5 - 10.0	8.4 - 10.0
	2.5" - 3"	5.4 - 8.5	5.3 - 8.4
	3"	3.6 - 5.4	3.5 - 5.3
	4"	2.7 - 3.6	2.6 - 3.5
750	2.5" - 3"	6.4 - 10.0	6.4 - 10.0
	3"	4.6 - 6.4	4.6 - 6.4
	4"	3.1 - 4.6	3.1 - 4.6
800	2.5" - 3"	6.8 - 10.0	7.0 - 10.0
	3"	4.6 - 6.8	4.8 - 7.0
	4"	3.3 - 4.6	3.5 - 4.8

Note: Some units list two diameters because the gas train increases in size after the regulating valve. The first number is the customer connection size.

UNDERSIZE
STANDARD
OVERSIZE

Table is based on Siemens gas train, which includes a regulating actuator.

Table A2-17. Recommended NTI Gas Train Sizes and Pressure Ranges

Boiler HP	4WI 15 PPM			4WI 9 PPM	
	Gas Train Size, in	Pressure Range PSI		Gas Train Size, in	Pressure Range PSI
100	1.5	2.3 - 5.0		1.5	2.3 - 5.0
125	1.5	3.3 - 6.0		1.5	3.3 - 6.0
150	1.5	3.9 - 6.0		1.5	4.1 - 6.0
200	1.5	4.5 - 7.0		1.5	4.5 - 7.0
250	1.5 - 2	4.5 - 7.0		1.5 - 2	4.2 - 7.0
300	1.5 - 2	6.1 - 9.0		1.5 - 2	5.9 - 9.0
	2	4.8 - 6.1		2	4.6 - 5.9
350	1.5 - 2	5.1 - 7.5		1.5 - 2	6.2 - 9.0
	2	4.0 - 5.1		2	5.2 - 6.2
				2.5	4.5 - 5.2
400	1.5 - 2	7.3 - 10.0		1.5 - 2	7.2 - 10.0
	2	5.8 - 7.3		2	5.7 - 7.2
	2.5	5.0 - 5.8		2.5	4.9 - 5.7
	3	4.1 - 5.0			
500	1.5 - 2	8.1 - 10.0		1.5 - 2	8.1 - 10.0
	2	6.1 - 8.1		2	6.1 - 8.1
	2.5	4.7 - 6.1		2.5	4.7 - 6.1
	3	3.4 - 4.7		3	3.4 - 4.7
600	2 - 3	7.8 - 10.0		2 - 3	7.8 - 10.0
	2.5 - 3	5.8 - 7.8		2.5 - 3	5.8 - 7.8
	3	4.4 - 5.8		3	4.4 - 5.8
700	2.5 - 3	7.7 - 10.0		2.5 - 3	7.9 - 10.0
	3	5.9 - 7.7		3	6.1 - 7.9
720				2.5 - 3	8.1 - 10.0
				3	6.3 - 8.1
750	2.5 - 3	8.6 - 10.0			
	3	6.7 - 8.6			

Note: Some units list two diameters because the gas train increases in size after the regulating valve. The first number is the customer connection size.

UNDERSIZE
STANDARD
OVERSIZE

Table is based on Siemens gas train, which includes a regulating actuator.

Table A2-18. Predicted Sound Levels (30 ppm NOx system) at High Fire - Model 4WI

BHP	Sound Level-dBA
100	79
125	83
150	83
200	84
250	83
300	84
350	84
400	85
500	85
600	87
700	88
800	90

ENGINEERING DATA

Sound Level

Table A2-18 gives a summary of predicted sound pressure levels for the CB boilers with 30 ppm LE Options. Contact your local Cleaver-Brooks authorized representative for sound levels for other LE Options.

Units

The units for the sound level tables are dbA (decibels, measured on the A-weighted scale) in reference to 0.0002 microbars (20 micro-Newtons per square meter). Their reference are standardly used in specifying and reporting sound pressure levels on industrial equipment.

Test Method

The sound pressure levels in the above tables were obtained from tests in accordance with the "ABMA Test Code for the Measurement of Sound from Packages Boilers." In accordance with this code the sound pressure levels reported were measured on the boiler centerline 4-1/2 feet vertically above the bottom of the base rails and 3 feet horizontally in front of the end of the blower motor or front surface of the electrical cabinet.

Sound Level Meter

The sound level meter used complies with ANSI S1.4, Type 1 (Precision). The readings are taken with the meter set for slow response and corrected for background levels.

Sound Pressure

With larger sized boilers, the need for auxiliary equipment, and the necessary interconnecting piping make it impractical (and sometimes impossible) to provide a boiler testing environment which is suitable for taking the data needed to develop Sound Pressure Power levels.

Typical Values

Sound pressure levels (dbA) for the same boiler will vary between boiler rooms. Sound levels will vary with motor type, NO_x levels, and altitudes. In addition, variations will occur between different people using different sound meters on the same boiler. And finally, no two boilers can be expected to give precisely the same sound levels. For these reasons, we can only predict, but not guarantee, sound levels (dbA).

Gas-Fired Burners

Table A2-16 shows gas pressure ranges for standard, oversized, and undersized gas trains.

Table A2-19 shows minimum required gas pressure altitude conversion.

C-B O₂ Trim Systems: If a C-B O₂ Trim system will be utilized, contact your local Cleaver-Brooks authorized representative to be sure that a compatible regulator is selected.

Table A2-20 shows maximum gas consumption for natural gas and propane vapor.

Table A2-21 shows standard gas train sizes and locations for Model CB Firetube Boilers.

Figure A2-4 shows typical gas train piping layouts for multiple boiler applications.

Oil-Fired Burners

Fuel oil consumption information is shown on the boiler rating sheets in the Dimensions and Rating Section.

Table A2-23 shows the oil connection sizes and locations for Model CB Boilers firing No. 2 oil.

Figures Figure A2-5 through Figure A2-8 show typical oil systems and layouts.

Figure A2-8 show the detail of an oil transfer tank (day tank) typically utilized to provide a storage reservoir between the oil system supply pump and the boiler oil pump.

Table A2-19. Minimum Required Gas Pressure Altitude Conversion

ALTITUDE (FT)	CORRECTION FACTOR	ALTITUDE (FT)	CORRECTION FACTOR
1000	1.04	6000	1.25
2000	1.07	7000	1.30
3000	1.11	8000	1.35
4000	1.16	9000	1.40
5000	1.21	-	-

To obtain minimum required gas pressure at altitudes above 700 feet, multiply the pressure by the listed factors:

- Inches WC x 0.577 = oz/sq-in.
- Oz/sq-in x 1.732 = Inches WC
- Inches WC x 0.0361 = psig.
- Oz/sq-in x 0.0625 = psig.
- Psig x 27.71 = Inches WC
- Psig x 16.0 = Oz/sq-in.

Table A2-20. Maximum Gas Consumption (CFH) for Natural Gas and Propane Vapor

BOILER HP	TYPE OF GAS AND HEAT CONTENT	
	NATURAL GAS 1000 (Btu/cu-ft)	PROPANE GAS 2550 (Btu/cu-ft)
125	5103	2000
150	6124	2402
200	8165	3202
250	10206	4002
300	12247	4802
350	14280	5600
400	16329	6404
500	20415	8006
600	24494	9605
700	28576	11206
750	30618	12007
800	32659	12807

BOILER HP	MODEL 4WI	
	CONNECTION SIZE (IN.) (NPT)	LOCATION DIMENSION "A" (IN.)
100-125	1-1/2	52
150-200	1-1/2	47-1/2
250-400	2	50
500	2-1/2	60
600	2-1/2 - 3	71
700-800	3	65

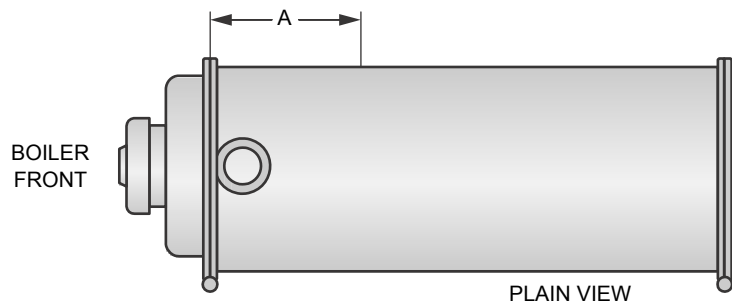
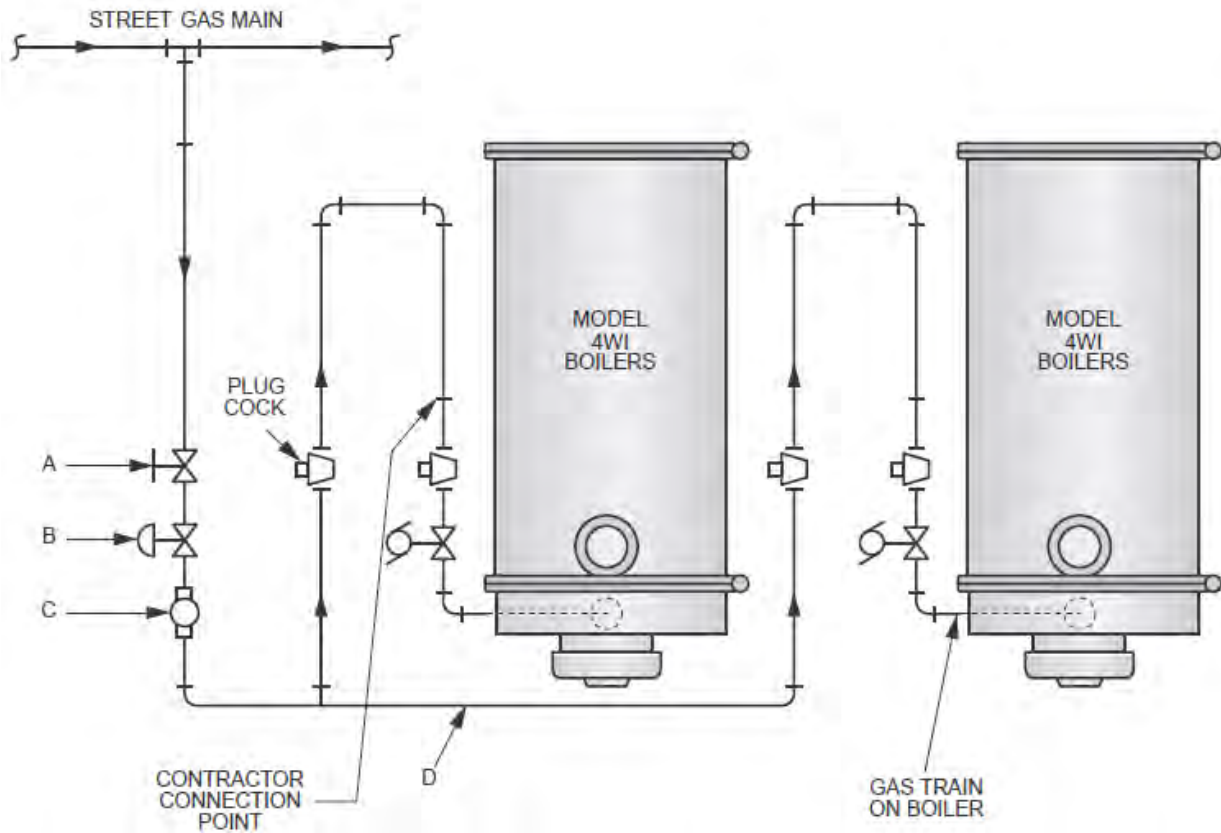

Table A2-21. Standard Gas Train Connection Size and Location

This figure illustrates the basic gas valve arrangement on Cleaver-Brooks Model 4WI boiler and shows the contractor’s connection point. The valves and controls between the contractor connection point and the gas main in the street are representative of a typical installation. Actual requirements may vary depending on local codes or local gas company requirements which should be investigated prior to preparation of specifications and prior to construction.



- A. Utilities service valve.
- B. Utilities service regulator.
- C. Gas meter.
- D. Piping from meter to boiler.

The size of the gas line from the meter to the gas pressure regulator at the boiler can be very important if gas pressures are marginal. The gas line sizing is dependent on:

1. Gas pressure at outlet of gas meter (C)
2. Rate of gas flow required, CFH
3. Length of pipe run (D)
4. Pressure required at contractor connection point.

The local gas utility will advise the pressure that is available at the outlet of their meter.

Figure A2-4. Typical Gas Piping Layout

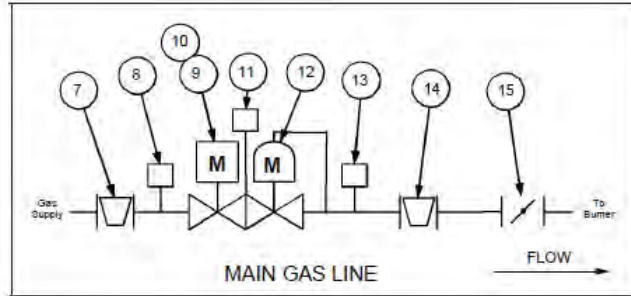
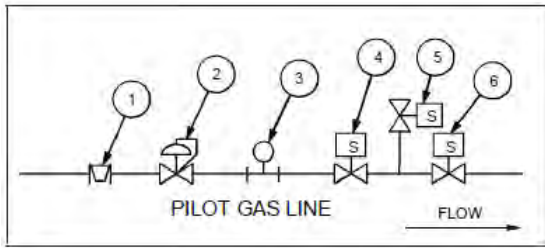

ITEM	DESCRIPTION	UL		FM		CSD-1	NFPA-85
		125 hp - 300 hp	350 hp - 800 hp	125 hp - 300 hp	350 hp - 800 hp	125 hp - 300 hp	350 hp - 800 hp
1	Pilot Shut Off Cock	X	X	X	X	X	X
2	Pilot Pressure Regulator	X	X	X	X	X	X
3	Pilot Pressure Gauge	X	X	X	X	X	X
4	Gas Pilot Valve	X	X	X	X	X	X
5	Pilot Vent Valve						X
6	Gas Pilot Valve						X
7	Manual Shut Off Valve	X	X	X	X	X	X
8	Low Gas Pressure Switch	X	X	X	X	X	X
9	Main Gas Valve w/o POC	X	X	X		X	
10	Main Gas Valve w/ POC				X		X
11	Vent Valve or Valve Proving Switch		X		X		X
12	Regulating Gas Valve w/ POC	X	X	X	X	X	X
13	High Gas Pressure Switch	X	X	X	X	X	X
14	Manual Shut Off Valve	X	X	X	X	X	X
15	Butterfly Valve	X	X	X	X	X	X

Table A2-22. Gas Train Components

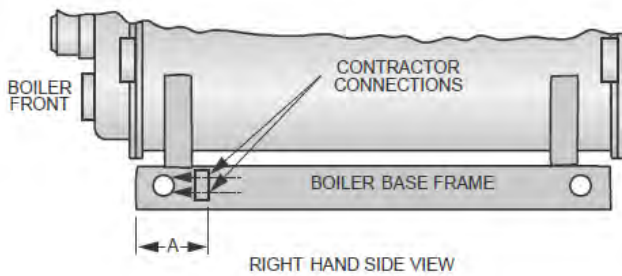

BOILER HP	SUPPLY AND RETURN CONN SIZES (IN.) (NPT)	A (IN.)	MODEL 4WI		
			RECOMMENDED OIL LINE ^A SIZES (STANDARD PIPE) (IN. - IPS)		
			STORAGE TANK TO BOILER OR PUMP CONNECT	PUMP TO BOILER	RETURN LINE TO TANK
100 150 200	3/4	12-1/2	1	1	1
250 300 350	3/4	34	1	1	1
400 500 600	3/4	11-3/4	1	1	1
700 750 800	1	11-3/4	1	1	1

NOTE: See No. 2 Oil Line Sizing Instruction for systems with other conditions.

A. For suction line condition with a maximum of 10 Feet of lift and a total of 100 feet of suction line.

Table A2-23. No. 2 Oil Connection Size, Location and Recommended Line Sizes

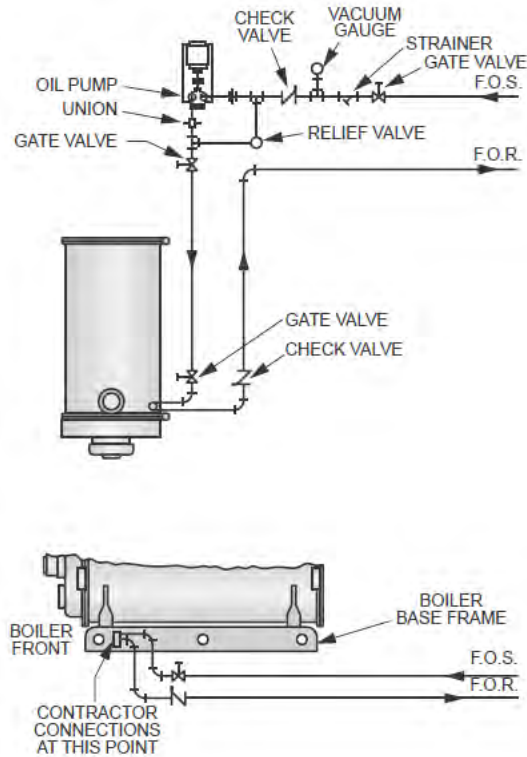

Figure A2-5. No. 2 Oil Piping, Single Boiler Installation, Remote Oil Pump

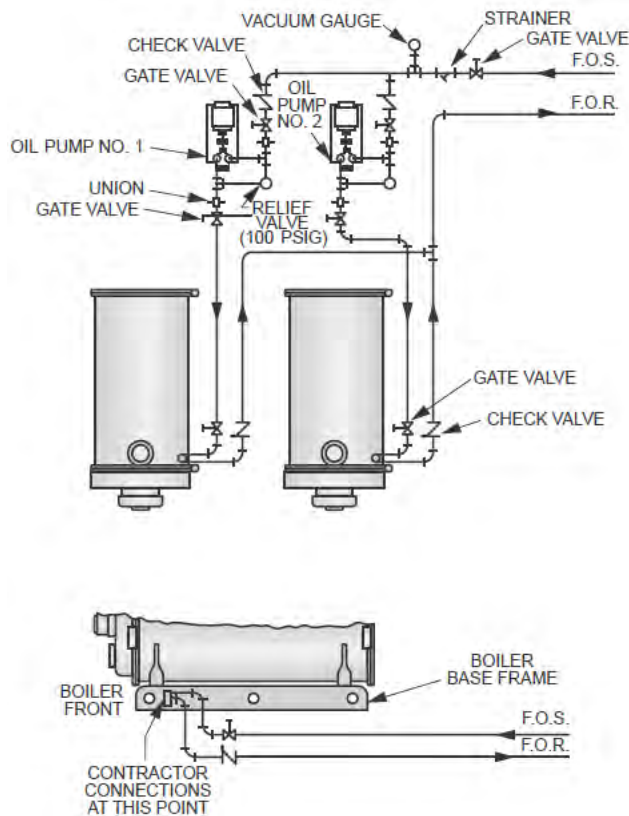

Figure A2-6. No. 2 Oil Piping, Multiple Boiler Installation, Remote Oil Pumps

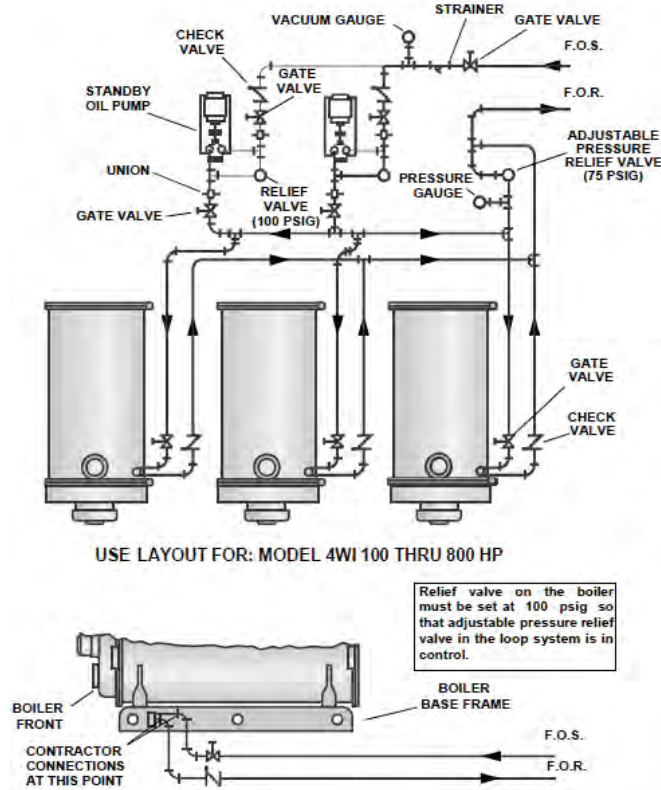

Figure A2-7. No. 2 Oil Piping, Multiple Boiler Installation

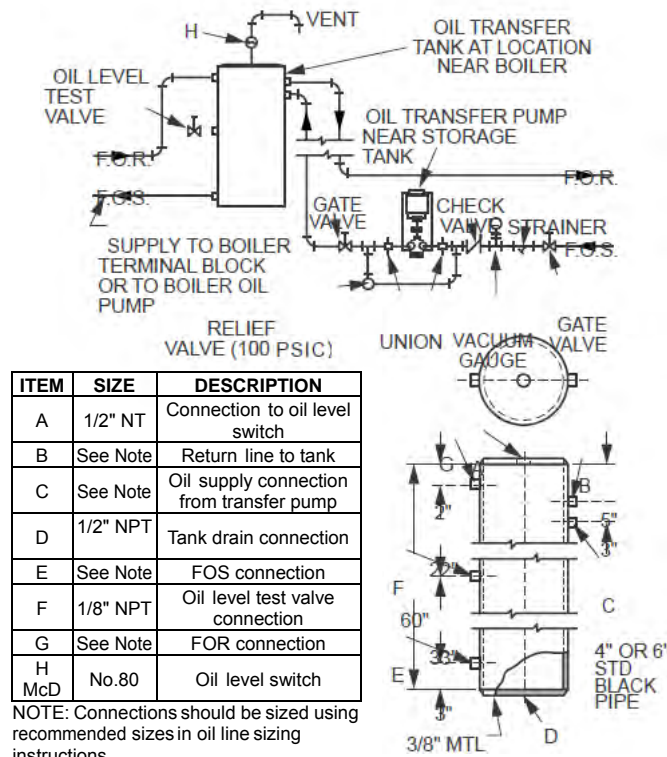
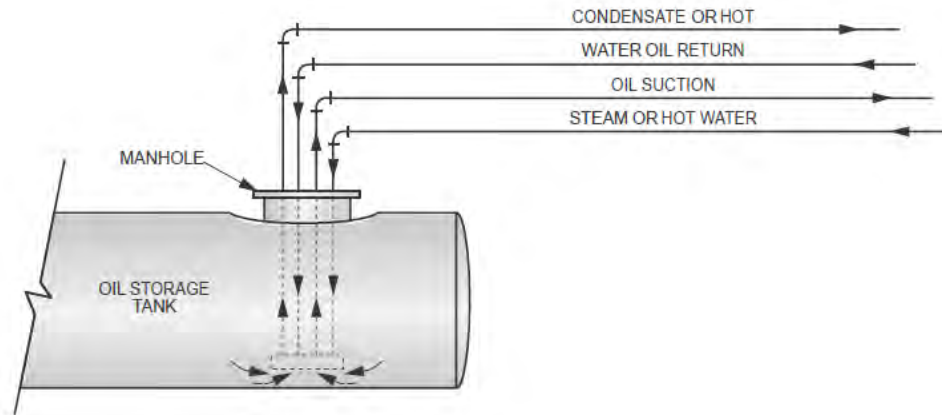

Figure A2-8. No. 2 Oil Transfer Tank Detail (For consideration with elevated boiler rooms)



Note: Observe all local and national (eg. Fire underwriters) code requirements governing the installation of fuel oil storage tanks and supply systems.

Figure A2-9. Typical Fuel Storage Tank Arrangement

General Boiler Information

Table A2-24 shows blowdown tank sizing information.

Table A2-25 provides heating surface information.

Table A2-26 provides steam volume and disengaging area information.

Table A2-27 provides recommended steam nozzle sizes.

Table A2-28 provides recommended non-return valve sizes.

Boiler Room Information

Figure A2-10 shows typical boiler room length requirements.

Figure A2-11 shows typical boiler room width requirements.

Figure A2-12 shows typical breeching arrangements.

Stack Support Capabilities

All standard Cleaver-Brooks Firetube Boilers can support up to 2,000 lbs without additional support.

Boilers 250 hp through 800 hp can be reinforced to support 3,000 lbs.

Stack/Breeching Size Criteria

The design of the stack and breeching must provide the required draft at each boiler flue gas outlet. Proper draft is critical to burner performance.

Although constant pressure at the flue gas outlet is not required, it is necessary to size the stack/breeching to limit flue gas pressure variation. The allowable pressure range is -0.25 " W.C. to $+0.25$ " W.C.

Boiler Room Combustion Air

When determining boiler room air requirements, the size of the room, air flow, and velocity of air must be reviewed as follows:

1. Size (area) and location of air supply openings in boiler room.
 - A. Two (2) permanent air supply openings in the outer walls of the boiler room are recommended. Locate (1) at each end of the boiler room, preferably below a height of 7 feet. This allows air to sweep the length of the boiler.

- B. Air supply openings can be louvered for weather protection, but they should not be covered with fine mesh wire, as this type of covering has poor air flow qualities and is subject to clogging by dust or dirt. A vent fan in the boiler room is not recommended, as it could create a slight vacuum under certain conditions and cause variations in the quantity of combustion air. This can result in unsatisfactory burner performance.
- C. Under no condition should the total area of the air supply openings be less than (1) square foot.
- D. Size the openings by using the formula: $\text{Area (sq-ft)} = \text{CFM/FPM}$
- 2. Amount of air required (cfm).
 - A. Combustion Air = Rated bhp x 8 cfm/bhp.
 - B. Ventilation Air = Maximum bhp x 2 cfm/bhp
 - C. Total recommended air = 10 cfm/bhp - up to 1000 feet elevation. Add 3 percent more per 1000 feet of added elevation.
- 3. Acceptable air velocity in Boiler Room (fpm).
 - A. From floor to (7) foot height - 250 fpm
 - B. Above (7) foot height - 500 fpm

Example: Determine the area of the boiler room air supply openings for (1) 300 hp boiler at 800 feet altitude. The air openings are to be 5 feet above floor level.

- Air required: $300 \times 10 = 3000$ cfm (from 2B above).
- Air velocity: Up to 7 feet = 250 fpm (from 3 above).
- Area Required: $\text{Area} = \text{cfm} / 250 = 3000 / 250 = 12$ sq-ft total.
- Area/Opening: $12 / 2 = 6$ sq-ft/opening (2 required).

Notice

Consult local codes, which may supersede these requirements.

Table A2-24. Blowdown Tank Sizing Information

BOILER HP	WATER (GAL)
100	85
125	104
150	102
200	131
250	145
300	169
350	178
400	198
500	233
600	278
700	286
800	286

NOTE: Quantity of water removed from boiler by lowering normal water line 4".

Table A2-25. Heating Surface

BOILER HP	HEATING SURFACE (SQ-FT)	
	FIRESIDE	WATERSIDE
100	500	
125	625	679
150	750	820
200	1000	1092
250	1250	1346
300	1500	1623
350	1750	1932
400	2000	2151
500	2500	2691
600	3000	3262
700 & 800	3500	3810

Table A2-26. Steam Volume Disengaging Area

BOILER HP	STEAM VOLUME CU-FT		STEAM RELIEVING AREA SQ-IN	
	HIGH PRESSURE (A)	LOW PRESSURE (B)	HIGH PRESSURE (A)	LOW PRESSURE (B)
100	16.5	22.3	4565	4954
125	20.3	27.4	5587	6077
150	19.9	26.8	5443	5918
200	25.7	34.6	7013	7632
250	34.8	49.5	7790	8597
300	40.6	57.9	9115	10051
350	51.3	69.6	9734	10570
400	57.2	77.5	10843	11779
500	83.6	107.6	12874	13781
600	100	128.6	15394	16474
700	115.6	144.9	15826	16819
800	115.6	144.9	15826	16819

NOTE:

- 1. Based on normal water level.
- A. Based on 150 psig design pressure.
- B. Based on 15 psig design pressure.

Table A2-27. Recommended Steam Nozzle Size (To Maintain 4000 to 5000 fpm Nozzle Velocity)

Model 4WI Recommended Steam Nozzle Size

OPERATING PRESSURE PSIG	BOILER HP											
	100	125	150	200	250	300	350	400	500	600	700	800
15	8	8	8	10	10	12	12	12	12	12	12	12
30	6	6	6	8	8	8	10	10	10	12	12	12
40	6	6	6	6	8	8	8	10	10	10	12	12
50	4	6	6	6	6	8	8	8	10	10	10	12
75	4	4	4	6	6	6	8	8	8	8	10	10
100	4	4	4	6	6	6	6	8	8	8	8	10
125	4	4	4	4	6	6	6	6	8	8	8	8
150	2.5	3	3	4	4	6	6	6	6	6	8	8
200	2.5	2.5	3	4	4	4	4	6	6	6	6	6
250	2	2.5	3	3	4	4	4	4	6	6	6	6

NOTES:

1. Steam nozzle sizes given in inches.
2. Recommended steam nozzle sizes based on 4000 to 5000 fpm steam velocity.
3. All standard steam nozzle sizes for 150 psig design pressure or greater are the same as 125 psig operating pressure on the above table. To increase or decrease the standard size, request the change with your local Cleaver-Brooks authorized representative.
4. Shaded area denotes special surge load baffles must be installed to avoid possible water carryover.
5. For incremental operating pressure, see Table I3-1 Steam System Fundamentals.

Table A2-28. Recommended Non-Return Valve Size

BOILER HP	BOILER CAPACITY (LBS/HR)	OPERATING PRESSURES (PSIG)							
		50	75	100	125	150	175	200	250
100	3450	2-1/2	2-1/2	NA	NA	NA	NA	NA	NA
125	4313	3	2-1/2	2-1/2	2-1/2	NA	NA	NA	NA
150	5175	3	3	2-1/2	2-1/2	2-1/2	2-1/2	NA	NA
200	6900	3*	3	3	3	3	2-1/2	2-1/2	2-1/2
250	8625	4	3*	3	3	3	3	3	
300	10350	4	4	4	3*	3	3	3	
350	12025	4	4	4		4	3*	3	3
400	13800	5	4	4		4	4		3*
500	17210	6	5	5		4	4	4	
600	20700	6	6	5		5	4	4	
700	24150	6	6	6		5	5	5	
800	27600	6	6	6		6	5	5	

NOTE: Valve sizes (300 # Flanges) given in inches.

Standard Non-Return valve selections limited to a maximum 2 to 1 turndown (50% of full load); selections based on typical non-return valve sizing recommendations. For final valve selection contact your C-B authorized representative. For high turndown applications see Boiler Book Section I3, Table I3-3.

* Indicates pressure drop of less than 7.5 psig. All other selections are less than 6 psig pressure drop.

Table A2-29. Blower Motor Selection 4WI NTI Boilers

Altitude: 700 ft and less - Design Pressure: 150 psi and less

Nominal Boiler Size	15 ppm Blower Motor HP	9 ppm Blower Motor HP
100	3	3
125	75	75
150	5	75
200	10	15
250	10	10
300	20	20
350	15	20
400	25	40
500	25	30
600	50	50
700	0	75
800	75	75

* 800 HP to be derated to 720 HP for 9 ppm and 750 HP for 15 ppm.

Table A2-30. Turndown Guarantee 4WI NTI Boilers - Natural Gas & #2 Oil

Boiler Size	Turndown	
	9 ppm	15 ppm
100	4:1	4:1
125	4:1	4:1
150	4:1	5:1
200	4:1	5:1
250	5:1	5:1
300	5:1	5:1
350	5:1	5:1
400	5:1	6:1
500	5:1	6:1
600	6:1	6:1
700	7:1	7:1
800*	7:1	7:1

* 800 HP to be derated to 720 HP for 9 ppm and 750 HP for 15 ppm.



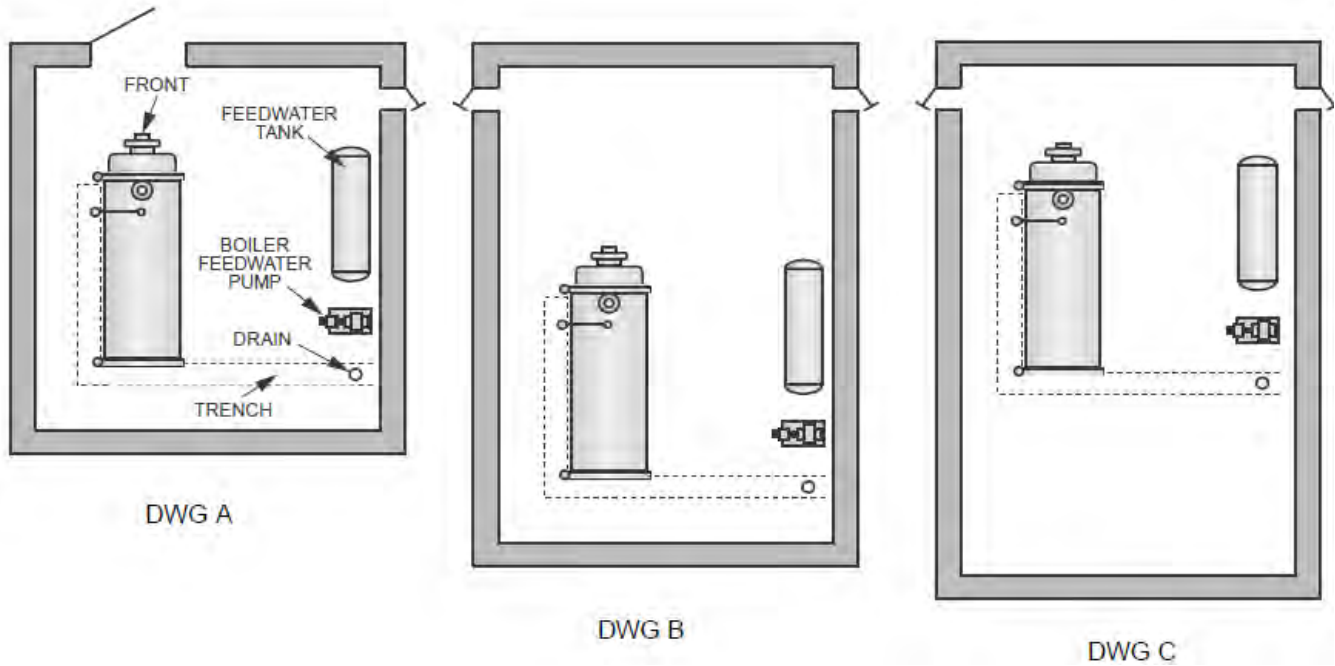

1. Shortest boiler room length (DWG A) is obtained by allowing for possible future tube replacement (from front or rear of boiler) through a window or doorway. Allowance is only made for minimum door swing at each end of the boiler. This arrangement provides sufficient aisle space at the front of the boiler but a “tight” space condition at the rear.

If space permits, approximately 1.5 additional feet should be allowed at the rear for additional aisle and working space.

2. Next shortest boiler room length (DWG B) is obtained by allowing for possible future tube replacement from the front of the boiler. Allowance is only made for minimum door swing at the rear.

If space permits, approximately 1.5 additional feet should be allowed at the rear for additional aisle and working space.

3. A slightly longer boiler room (DWG C) is obtained by allowing for possible future tube replacement from the rear of the boiler. Allowance for door swing at the front provides sufficient aisle and working space at the front.

Figure A2-10. Boiler Room Length (Typical Layouts)

BOILER HP	100 125	150 200	250 300	350 400	500 600	700 800
Dimension A	87	91"	96"	100"	105	110
Dimension B	120	127"	144"	151"	174	184

NOTES:

1. Recommended Minimum Distance Between Boiler and Wall. Dimension “A” allows for a “clear” 42” aisle between the wa- ter column on the boiler and the wall. If space permits, this aisle should be widened.
2. Recommended Minimum Distance Between Boilers. Dimension “B” between boilers allows for a “clear” aisle of:
 42” - 125 -200 hp
 48” - 250-350 hp
 60” - 400-800 hp
 If space permits, this aisle should be widened.

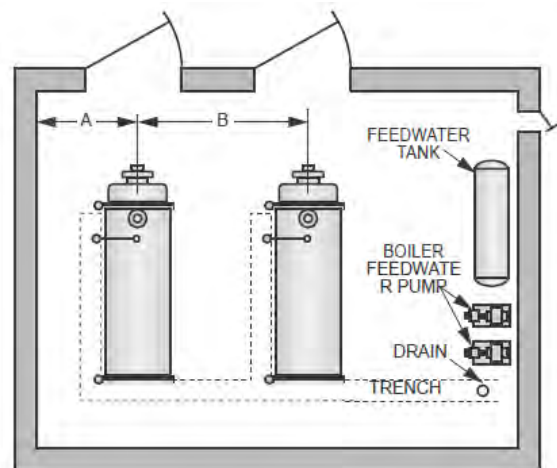
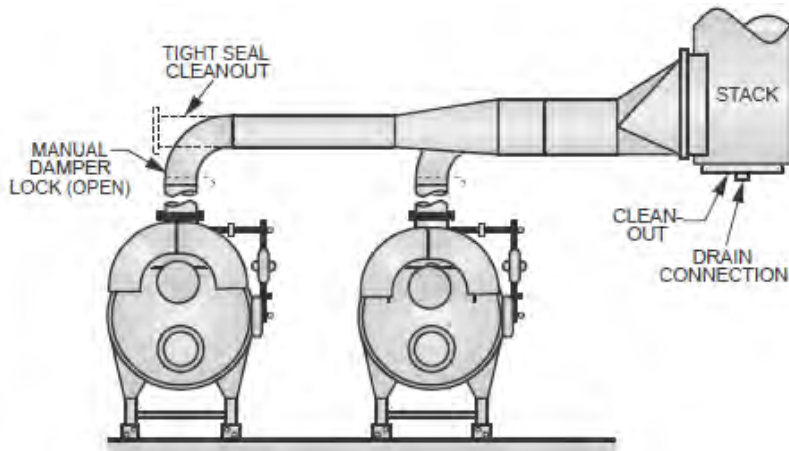

Figure A2-11. Boiler Room Width (Typical Layout)



MULTIPLE BOILERS WITH A COMMON STACK

NOTE: These stack breaching arrangements for multiple boilers are typical and not intended for your specific design requirements. For additional information, review Section F, Stacks.

Stack and breaching sizes should always be provided by a reputable stack supplier who will design the stack and breaching system based on your specific criteria. Your local Cleaver-Brooks authorized representative is capable of assisting in your evaluation of stack and breaching design.

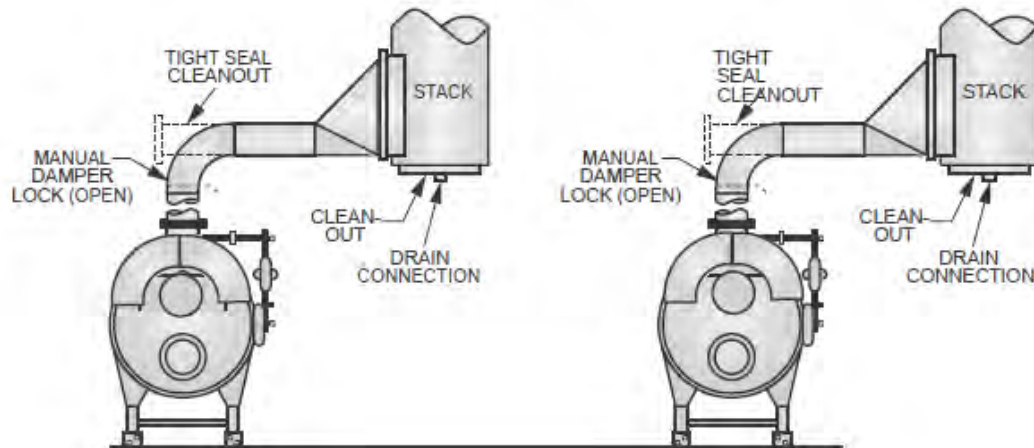
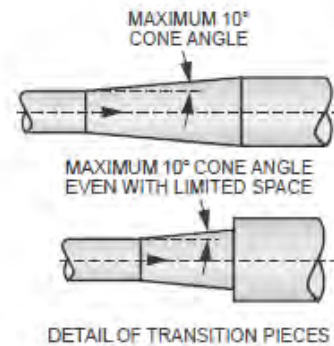

MULTIPLE BOILERS WITH INDIVIDUAL STACKS

Figure A2-12. Breaching Arrangement

SAMPLE SPECIFICATIONS - MODEL 4WI STEAM BOILERS

PART 1 GENERAL

1.1 SCOPE

- A. The work to be performed consists of providing all labor, equipment, materials, etc. to furnish and install new factory assembled steam boiler(s) as described in the specifications herein.

1.2 REFERENCES

- A. Product Data: Include rated capacities; shipping, installed, and operating weights; furnished specialties; and accessories for each model indicated.
- B. Shop Drawings: Detail equipment assemblies and indicate dimensions, required clearances, and method of field assembly, components, and location and size of each field connection.
- C. Wiring Diagrams: Detail wiring for power, signal, and control systems and differentiate between manufacturer-installed and field-installed wiring.
- D. Source Quality Control Tests and Inspection Reports: Indicate and interpret test results for compliance with performance requirements before shipping.
- E. Field Test Reports: Indicate and interpret test results for compliance with performance requirements.
- F. Maintenance Data: Include parts list, maintenance guide, and wiring diagrams for each boiler.
- G. ASME Section I or IV (Power boilers or Heating Boilers)
- H. NSI Z21.13 (Gas Fired Low Pressure Boilers)
- I. NFPA 54 (ANSI Z221.3) National Fuel Gas Code
- J. Factory Mutual
- K. ASME CSD-1 (Controls and Safety Devices)
- L. XL-GAP (formerly GE-GAP GE Global Asset Protection)
- M. UBC (Uniform Building Code)
- N. MC (Uniform Mechanical Code)
- O. NEC (National Electrical Code)
- P. UL (Underwriters Laboratories)
- Q. NFPA 85

1.3 QUALITY ASSURANCE

- A. The equipment shall, as a minimum, be in strict compliance with the requirements of this specification and shall be the manufacturer's standard commercial product unless specified otherwise. Additional equipment features, details, accessories, appurtenances, etc. which are not specifically identified but which are a part of the manufacturer's standard commercial product, shall be included in the equipment being furnished.
- B. The equipment shall be of the type, design, and size that the manufacturer currently offered for sale and appears in the manufacturer's current catalogue. The equipment shall be new and fabricated from new materials and shall be free from defects in materials and workmanship.

- C. The equipment must fit within the allocated space, leaving ample allowance for maintenance and cleaning, and must leave suitable space for easy removal of all equipment appurtenances. Tube pull clearance space from either the front or rear of boiler must be maintained.
- D. All units of the same classification shall be identical to the extent necessary to insure interchangeability of parts, assemblies, accessories, and spare parts wherever possible.
- E. In order to provide unit responsibility for the specified capacities, efficiencies, and performance, the boiler manufacturer shall certify in writing that the equipment being submitted shall perform as specified. The boiler manufacturer shall be responsible for guarantying that the boiler provides the performance as specified herein.

1.4 SUBMITTALS

- A. The contractor shall submit, in a timely manner, all submittals for approval by the engineer. Under no circumstances shall the contractor install any materials until the engineer has made final approval on the submittals.
- B. The engineer shall review and stamp submittals. Work may proceed and equipment released for fabrication after contractor receives returned submittals stamped with "NO EXCEPTIONS TAKEN" or "MAKE CORRECTIONS NOTED".
- C. The bidder must submit in writing to the engineer any request for a proposed deviation, omission, modification, or substitution to this specification for evaluation no later than ten (10) days prior to the bid date. A request for any substitution shall be accompanied by technical data, drawings, product samples, and complete data substantiating compliance of proposed substitution with these specifications. No materials shall be deemed acceptable if not in strict and full compliance with these specifications. All bidders must bid solely on the specified materials unless acceptance by the engineer of a deviation, omission, modification, or substitution is granted in writing to all bidders prior to the bid date.
- D. Shop Drawings - Shop drawings shall be submitted to the engineer for approval and shall consist of:
 - E. General assembly drawing of the boiler including product description, model number, dimensions, clearances, weights, service sizes, etc.
 - F. Schematic flow diagram of gas valve trains.
 - G. Schematic wiring diagram of boiler control system of the ladder-type showing all components, all interlocks, etc. Schematic wiring diagram shall clearly identify factory wiring and field wiring.
 - H. Installation Instructions: Manufacturer's printed instructions for installation shall be submitted to the engineer for approval.
 - I. Manufacturer's Warranties: Manufacturer's printed warranties, as specified hereinafter, shall be submitted prior to final acceptance by the engineer.
 - J. Manufacturer's Field Service: Manufacturer's printed field service procedures and reports, as specified hereinafter, shall be submitted prior to final acceptance by the engineer. Report forms shall contain all information as required to do start-up and testing as specified in the products section.

1.5 CERTIFICATIONS

- A. Manufacturer's Certification: The boiler manufacturer shall certify the following:
 - 1. The products and systems furnished are in strict compliance with the specifications.
 - 2. The boiler, burner and other associated mechanical and electrical equipment have all been properly coordinated and integrated to provide a complete and operable boiler.
 - 3. ASME certification.
 - 4. UL and CSD-1 certification.
 - 5. The equipment furnished has been installed in accordance with the manufacturer's installation instructions.
 - 6. The specified factory tests have been satisfactorily performed.
 - 7. The specified field tests have been satisfactorily performed.
- B. Contractor's Certification: The contractor shall certify the following:
 - 1. The products and systems installed are in strict compliance with the specifications.
 - 2. The specified field tests have been satisfactorily performed.
- C. Boiler Inspectors' Certification: All boiler inspections during hydrostatic testing shall be performed by an authorized boiler inspector who is certified by the National Board of Boiler and Pressure Vessel Inspectors and shall be submitted in writing prior to final acceptance by the engineer.
- D. Test Reports: Factory and field test reports as described above and as specified hereinafter, shall be submitted prior to final acceptance by the engineer.
- E. Operation and Maintenance Manuals: Manufacturer's printed operation and maintenance manuals shall be submitted prior to final acceptance by the engineer. Operation and maintenance manuals shall contain shop drawings, product data, operating instructions, cleaning procedures, replacement parts list, maintenance and repair data, complete parts list, etc.

1.6 DELIVERY, STORAGE, AND HANDLING

- A. The contractor shall be responsible for the timely delivery of the equipment to the job site. The contractor shall be responsible for unloading and rigging of the equipment. The contractor shall be responsible for protecting the equipment from the weather, humidity and temperature conditions, dirt, dust, other contaminants, as well as job site conditions during construction.
- B. Equipment shall be unloaded, handled, and stored in accordance with the manufacturer's handling and storage instructions.
- C. The work to be performed consists of providing all labor, equipment, materials, etc. to furnish and install new factory assembled, low pressure hot water boilers as described in the specifications herein.

PART 2 PRODUCTS**2.1 MANUFACTURERS**

- A. Contractor shall furnish and install Cleaver Brooks Model 4WI natural gas (combination Gas/Oil fired) steam boiler(s) with design pressure as scheduled on the drawings.
- B. Alternate manufacturers complying with plans and specifications must be submitted and approved by the consulting engineer within 10 days prior to bid date.

2.2 GENERAL DESCRIPTION

Factory packaged unit shall include boiler, burner, heavy duty skids, painted steel jacket with two inches of fiberglass insulation, controls and accessories all piped and wired for single point field connections. Units shall carry packaged label of Underwriters Laboratory (UL) and be in accordance with ASME/CSD-1, all codes required by the local governing authorities and as indicated on the design performance data sheet. A certified factory fire-test shall be provided on all fuels with data sheets furnished to Engineer and Owner. ASME certified, labeled, stamped and designed for _____ PSIG steam in accordance with Section (I or IV) of ASME Code. Unit shall be designed to Seismic Zone requirements and be provided with tie down clips and calculations showing bolt diameter requirements. Manufacturer's Representative to provide services for field testing and adjusting of boiler and controls to meet design requirements.

2.3 PERFORMANCE: BOILER SIZE AND RATINGS

- A. The capacity of each unit shall be indicated on the drawing schedule.
- B. Performance Criteria:

Performance Criteria	
Manufacturer:	CLEAVER-BROOKS
Model:	Promethean Line
Horsepower:	_____ HP
Output:	_____ #/hr (from and at 212°F)
Gas Input:	_____ MBH
Oil Input:	_____ GPH
Design Pressure:	_____ PSIG
Operating Pressure	_____ PSIG
Steam Disengaging Area (minimum)	_____ Sq. Inches
Steam storage area (minimum)	_____ Cu. Ft.
Heating Surface (minimum):	_____ Sq. Ft. Fireside
Heating Release (maximum):	_____ BTU/Cu. Ft
Burner Turndown Ratio Natural Gas:	
Overall Efficiency (Fuel to Steam)	
Natural Gas (%):	_____ % at High Fire
No. 2 Oil (%):	_____ % at High Fire
NOX Emission (maximum)	
Gas (Natural):	_____ PPM (corrected to 3%O ₂)
Oil (No. 2):	_____ PPM (corrected to 3%O ₂)
CO Emissions (maximum)	
Gas (Natural):	_____ PPM (corrected to 3%O ₂)
Oil (No. 2):	_____ PPM (corrected to 3%O ₂)
Electrical:	_____ V / _____ H / _____ P
Fan Motor:	_____ HP
Air Compressor Motor:	_____ HP
Oil Pump Motor:	_____ HP
Noise Level (3' from burner):	_____ dBA
Available Gas Supply Pressure:	_____ PSIG
Weight	
Dry:	_____
Flooded:	_____
Seismic Zone:	_____
Altitude:	_____ ASL
Code Requirements:	ASME / NATIONAL BOARD CSD-1 NFPA 8501 Underwriter's Lab (UL) State Of _____ Factory Mutual (FM) Industrial Risk Insurers (IRI)



- C. Noise Sound Levels: Based on ABMA test code for packaged boilers measured 4-1/2 feet vertically above the bottom of the base rail and 3'0" horizontally in front of the end of the blower motor or front surface of control cabinet. Sound levels dBA on the scale in reference to 0.0002 microbars.

High Fire	#2 oil	dBA
Low Fire	#2 oil	dBA
High Fire	Nat Gas	dBA
Low Fire	Nat Gas	dBA

2.4 BOILER DESIGN

- A. Four pass steel scotch marine firetube boiler for positive pressurized firing with forced draft burner. Wet back design with a minimum five (5) square feet of heating surface per boiler horsepower. Front and rear doors shall be davited and sealed with tad-pole gaskets using heavy duty cap screws threaded into replaceable brass nuts. When opened, doors shall expose all tubes, tubesheets and furnace for ease of inspection and maintenance. Lifting loops shall be provided. Rear door shall be refractory lined with air cooled observation port. Tubes shall be rolled, beaded and/or welded into tube sheets and tubes shall be cleanable and removable from either front or back. Tubes shall be a minimum 2.5" O.D., with a tube wall thickness of not less than .095".
- B. The boiler pressure vessel shall be completely insulated with a minimum of 2" of insulation and shall be encased in an 18 gauge metal cabinet with primer and finish coat of paint.

2.5 BURNER DESIGN

- A. GENERAL: Forced draft burner mounted in and integral with boiler hinged front boiler door so when door is opened burner head, furnace, tubesheet and tubes are exposed; reversed curve cast aluminum blower fan; motor(s); ACCU-LINK single point positioning system consisting of rotary air damper located on fan discharge, straight line linkage and characterized cams; air flow switch; fuel trains and control panels. To conform to UL and other insurance requirements as indicated.
- B. GAS BURNER: Shall be of the high radiant multi-port type for natural gas. Minimum pilot safety burner shall consist of gas-electric spark ignition with 100% safety shut-off pilot, solenoid gas valve, pressure regulator and shut-off cock. Minimum main gas train shall include manual shut- off valve, pressure regulating valve, dual safety gas valves, manual test valve high-low pressure switches, manifold pressure gauge and butterfly gas valve with (14) point characterized cam assembly. Gas train shall be factory packaged to meet insurance requirements as indicated. Gas turn down shall be minimum _____. 4:1 up to 200 HP, 10:1 from 250 HP and above.
- C. OIL BURNER Oil burner shall be of the low pressure air atomizing type for No. 2 oil. Minimum pilot safety burner shall consist of gas-electric spark ignition with 100% safety shut-off pilot, solenoid gas valve, pressure regulator and shut-off cock. Oil train shall consist of retractable nozzle with flexible hoses; gauges, manifold block; air purge valve; fuel-oil controller with (14) point characterized cam assembly; dual oil solenoids; temperature switch, air compressor assembly and oil pump assembly. (For heavy oil, an oil preheat system shall be provided to include a water to water to oil safety type preheater and thermostatically controlled electric preheater.) Oil train

shall be factory packaged to meet insurance requirements as indicated. Oil turn down shall be minimum 8:1(250 hp-800 hp), 4:1 (up to 200 hp).

- D. COMBINATION BURNER: Provide gas-oil fuel selector switch to provide fuel switch over without any required adjustments to burner linkage.
- E. FUEL-AIR CONTROL: Modulating fire with proven low fire start. Provide manual potentiometer with manual-auto switch on boiler control panel in addition to automatic fuel-air controller. Linkage system shall be Cleaver-Brooks ACCU-LINK single point positioning with rotary air damper, linkage and (14) point characterized cam assembly for all fuels. Provide automatic operating control and manual reset high limit.
- F. FORCED DRAFT BLOWER: All air for combustion shall be supplied by a blower mounted in the front boiler door above the burner. The Backward curved cast aluminum radial impeller shall be directly connected to a flanged type ODP motor. This rigid mounting with the blower wheel inside the head shall eliminate vibration and reduce noise level. The balanced blower wheel shall be cast aluminum with radial blades. The combustion air damper shall be an integral rotating damper and shall be automatically adjusted for proper air quantity by a mod motor to maintain proper fuel-air ratios.
- G. EMISSION CONTROL: Boiler NO_x shall be furnished with guaranteed internal induced NO_x control for 60 PPM (30, 15 & <9 PPM NO_x systems are optional) corrected to 3% O₂ over the entire turndown range. Boiler capacity, turndown, flame stability and efficiency shall not be affected by the internal NO_x control. External FGR piping shall not be allowed. Low NO_x system shall be part of the Boiler/Burner UL package label and manufacture shall have Twelve (12) years of emission control experience in the state of _____.

2.6 BOILER TRIM

- A. To include the following:
 1. _____" diameter pressure gauge.
 2. ASME safety relief valve(s).
 3. Auxiliary Low Water Cutoff, Warrick 3C-2.
 4. Primary low water cut-off.
 5. Operating control.
 6. Limit control with manual reset.
 7. _____" stack thermometer.
 8. Feedwater regulating valve with 3 valve bypass
 9. Low fire hold controller (optional).
 10. 1 Slow Opening Blowdown Valve, Size _____", Class 200#
 11. 2 Quick Opening Blowdown Valves, Size _____", Class 490#
 12. Feedwater Globe Valve, Size _____", Class 240#
 13. 1 Feedwater Check Valve, Size _____", Class 240#
 14. 1 ASME Spool Piece, Inlet Size _____", Outlet Size _____", Length _____"
 15. 1 Stop Valve (Steam Header Valve), Size _____", Flanged, Cast Iron, Class 250"
 16. 1 Stop Check Valve (Non-Return Valve), Size _____", Flanged, Cast Iron, Class 250", Straight Pattern, with Free Blow Drain Valve

17. Factory mounted, installed, tested, and certified piping (by A, S, or PP ASME stamp holder) and valves per ASME Code, including:
 - Water Column piping
 - Bottom Blowdown (from boiler to last code valve)
 - Feedwater assembly (shipped loose)
 - Surface Blowdown piping with stop valve and metering valve.
 18. Modulating Feedwater Control Valve, including 3-Valve Bypass
 19. Oil Pump, Mounted and Wired
 20. Air Atomizing Compressor, Mounted and Wired
 21. Platforms and ladder to access steam header and safety relief valves. Built to OSHA requirements.
- B. WATER COLUMN/LOW WATER CUTOFF AND WATER LEVEL CONTROL SYSTEM (150-250 psig design): Shall be a CB LEVEL MASTER Water level control system and shall be comprised of a microprocessor-based electronic controller, a non-contact, non-wearing, continuously reading absolute level sensor and pressure chamber. The control system shall be designed as follows: The electronic controller shall be mounted in the common control panel and operate in ambient temperatures from 32 degrees F to 125 degrees F, the pressure chamber shall be boiler mounted and operate to pressures of 250 psig and the level sensor shall operate to pressures of 250 psig and temperatures to 400 degrees F. The pressure containing components shall be constructed in accordance with ASME Code. A shielded, four conductor cable with ground shall be run in metal conduit between the level sensor and the controller. Supply power shall be 115VAC-1 phase- 60 Hz. All wiring shall be in compliance with the National Electrical Code.
- The pressure chamber shall have a sight glass mounted on the side. The level sensor shall have an accuracy of .01" or greater. The electronic controller shall have level and error indicating lights, alphanumeric display for messaging, reset/menu switch and the following features:
1. Continuous Level Indication
 2. Low Water Cutoff & Alarm
 3. High Water Alarm
 4. Low & High Water Warning
 5. Full Modulating Control of Modulating Feedwater Control Valve
 6. Continuous Monitoring of Float Operation
 7. Column Blowdown Detection and Reminder
 8. Auto or Manual Reset
 9. Real Time Clock
 10. Alarm Annunciation
 11. Alarm History Files with Time Stamp
 12. Water Column Blowdown Record
 13. Auxiliary Low Water Cutoff Check
 14. RS 232 Interface
 15. Maximum Contacts Rating 15 amps Resistive Load

2.7 BOILER CONTROLS

- A. A common enclosure shall house the control panel and the entrance panel. Enclosure shall be NEMA 4 rated and shall be mounted at the side of the boiler in a location convenient to the operator. Enclosure shall consist of upper and lower sections divided by a partition with a separate hinged door for each section. Upper section (low voltage) will house boiler controls including flame safeguard, water level system controller, and Hawk ICS if so equipped. Lower panel section (high voltage) will house entrance panel.
- B. OPTION 1) BURNER MANAGEMENT SYSTEM (CB 780E Standard): Mounted at side of boiler in control panel enclosure. Microprocessor-based control to monitor all critical boiler and burner interlocks control and supervise burner light off sequence, and initiate an orderly safety procedure in the event of interlock or flame failure. Dynamic self checking. System to provide pre-post purge status, fault history, and diagnostic information by means of a two-line alpha-numeric display with alarm/status LEDs.

- C. (OPTION 2) CB-HAWK ICS Boiler Control Sstem (Optional upgrade): Integrated Boiler Control and Management System:

Boiler shall be factory equipped with a Boiler Control System combining a Digital Burner

Management System for flame safety, and a Programmable Logic Controller for boiler modulation and operator interface functions.

The factory pre-configured Boiler Control System shall integrate the Burner Management functions and the PLC based modulation and operator interface functions. The logic of the Burner Management System and the modulating controls will not be run in the same processor or powered by the same DC supply. The PLC and Operator Interface Hardware shall be as manufactured by Allen Bradley.

Major system components shall include:

- Programmable Logic Controller
- Touch Screen HMI
- One Burner Management Controller with Wiring Sub-Base
- One Flame Scanner and amplifier
- Various Temperature and Pressure Sensors

Major functions provided by the Boiler Control System shall be:

- Automatic sequencing of the boiler through standby, pre-purge, pilot flame establishing period, main flame establishing period, run, flame proving and lockout and post-purge
- Full modulating control of fuel and air
- Utilize solid state controls and sensors to provide various control functions, such as:

Modulating control (algorithm shall be Proportional-Integral-Derivative (PID) type)

Thermal shock protection

High and Low limit alarms and shutdowns

- Touch Screen graphical operator interface and monitoring
 - Manual control of the boiler firing rate using control screens on the HMI to increment or decrement the firing rate
 - On screen indication of burner management controller status and diagnostics
 - On screen display of system alarms and faults
 - On screen history of alarms and faults
 - On screen recommendations for troubleshooting of fault conditions
 - On screen water level indication and alarm(s)
- Stack Flue Gas, Combustion Air and Shell (water) temperature indication
- Boiler efficiency calculation
- Low Fire Hold with Minimum Temperature Control
- Assured Low Fire Cut-Off (ALFCO)

The Boiler Control System shall incorporate the following safety provisions:

- Examine all load terminals to assure it is capable of recognizing the true status of the external controls, limits and interlocks. If any input fails this test, the Burner Management System shall lockout on safety shutdown.
- Closed-loop logic test of critical loads (ignition, pilot and main fuel valves) and must be able to lockout on safety.
- Pre-ignition interlocks (fuel valve proof of closure, etc.) and flame signal checked during Standby and Pre-Purge.
- Dynamic checking of the flame signal amplifier.
- Safe start check and expand check to include monitoring flame signal during standby.
- High and Low fire switches checked for proper sequencing.

The Boiler Control System shall provide the ability to communicate with external digital via Ethernet as a standard. OPC compliant Internet communications shall be supported, with the Boiler Control System supplied with its own IP address.

2.8 SHOP TEST

- A. Shop test: The complete packaged boiler shall receive factory tests to check construction and function of all controls. All shop tests may be witnessed by the purchaser at his own c upon sufficient notice to the company.

2.9 ACCESSORIES - BOILER FLUE VENT

2.10 ACCESSORIES - FEEDWATER SYSTEM (BOILER FEEDSET OR DEAERATOR)

2.11 ACCESSORIES - FEEDWATER HEATER OR ECONOMIZER

2.12 ACCESSORIES - BLOWDOWN SEPARATOR AND/OR BLOWDOWN HEAT RECOVERY

2.13 ACCESSORIES – O₂ TRIM SYSTEM

2.14 ACCESSORIES - CHEMICAL FEED SYSTEM AND/OR WATER TREATMENT

2.15 MANUFACTURER FIELD SERVICES

- A. General: The boiler and accessories supplier shall be responsible for performance of inspections, start up and testing of the package boiler and accessory equipment and materials furnished under this section. A detailed written record of the start up performance, including burner setting data entire load range shall be furnished to the test engineer before test personnel leave the site. Equipment and test apparatus shall be furnished by the supplier. All equipment defects discovered by the tests shall be rectified. The minimum time for two (2) boilers is five (5) days.
- B. Equipment inspection: Boiler representative to provide _____ hours of job site assistance to inspect boilers and other equipment upon arrival, verifying completeness of equipment supplied or damages. Responsibility of making freight claims to be performed by contractor or owner personnel.
- C. Pre start-up walk through: Boiler representative shall spend _____ hours at job site reviewing with mechanical contractor to be conducted approximately 1 week prior to startup.
- D. Start-up shall be conducted by experienced and factory authorized technician in the regular employment of the boiler supplier, and shall include:
 1. Demonstrate that boiler, burner, controls and accessories comply with requirement Section as proposed by the boiler and accessories supplier. Pre-test all items prior to scheduling the final testing that will be witnessed by the test engineer.
 2. Readings at different firing rates (25, 50, 75 and 100%) of load for the modulating burner shall be taken with a written report of the tests submitted to the test engineer. The reports shall include readings for each firing rate tested and include stack temperatures, O₂, CO, NO_x and overall boiler efficiency.
 3. Auxiliary Equipment and Accessories: Observe and check all valves, draft fans, electric motors and other accessories and appurtenant equipment during the operational and capacity tests for leakage, malfunctioning, defects, and non compliance with referenced standards or overloading as applicable.
 4. Commissioning Requirements:
 - a). Fireside inspection
 - b). Waterside inspection
 - c). Closing and resealing of doors, manways and hand holes
 - d). Set up fuel train and combustion air system
 - e). Set up operating set points
 - f). Check all safeties, including: Flame safeguard, LWCO, ALWCO, Air flow, Fuel pressures, High limits
 - g). Set up and verify efficiencies at 25%, 50%, 75%, and 100%
 - h). Set up and verify burner turndown.
 - i). Set up and verify feedwater/level controls
 - j). Set up and verify Emissions Compliance
- E. Training to include all safety procedures, maintenance procedures, control operations, and diagnostic procedures.

Training to be provided in a single _____ hour continuous session to accommodate operator's availability on site.

2.16 OPERATING & MAINTENANCE MANUALS

- A. Provide two (2) Operating and Maintenance manuals including cut-away views of boiler and burner, schematics including fuel trains, general instructions for maintenance and inspections, complete spare parts lists and trouble shooting procedures.
- B. A wiring diagram corresponding to the boiler shall be affixed to the boiler near the electrical panel.

2.17 WARRANTY DATA

- A. The entire boiler/burner package shall be guaranteed and warranted by the boiler manufacturer. Warranty shall include all parts for a period of (12) months from the date of start-up or beneficial use or 18 months from shipment, whichever comes first.

PART 3 EXECUTION**3.1 GENERAL**

- A. Installation shall be provided by the contractor in accordance with the requirements of the codes specified hereinbefore. All of the contractor's work shall be performed by experienced workman previously engaged in boiler plant construction and shall be under the supervision of a qualified installation supervisor.

3.2 INSTALLATION

- A. Install equipment in strict compliance with manufacturer's installation instructions.
- B. Install equipment in strict compliance with state and local codes and applicable NFPA standards.
- C. Maintain manufacturer's recommended clearances around sides and over top of equipment.
- D. Install components that were removed from equipment for shipping purposes.
- E. Install components that were furnished loose with equipment for field installation.
- F. Provide all interconnecting electrical control and power wiring.
- G. Provide all fuel gas vent and service piping.
- H. Provide all piping for boiler pipe connections.

3.3 FIELD TESTING

- A. The manufacturer's representative shall test all boiler and burner interlocks, actuators, valves, controllers, gauges, thermometers, pilot lights, switches, etc. Any malfunctioning component shall be replaced.
- B. All adjustments to boiler, burner, and boiler control system shall be performed by the manufacturer's representative.

3.4 START-UP, INSTRUCTION AND WARRANTY SERVICE

The manufacturer's representative shall provide start-up and instruction of each new boiler, including burner and boiler control system as specified herein. Start-up and instruction shall cover all components assembled and furnished by the manufacturer whether or not of his own manufacture.

SAMPLE SPECIFICATIONS - MODEL 4WI HOT WATER BOILERS

PART 1 GENERAL

1.1 SCOPE

The work to be performed consists of providing all labor, equipment, materials, etc. to furnish and install new factory assembled steam boiler(s) as described in the specifications herein.

1.2 REFERENCES

- A. ASME Section IV (Heating Boilers)
- B. ANSI Z21.13 (Gas Fired Low Pressure Boilers)
- C. NFPA 54 (ANSI Z221.3)
- D. National Fuel Gas Code
- E. FACTORY MUTUAL
- F. ASME CSD-1 (Controls and Safety Devices)
- G. GE-GAP (GE Global Asset Protection)
- H. UBC (Uniform Building Code)
- I. UMC (Uniform Mechanical Code)
- J. NEC (National Electrical Code)
- K. UL (Underwriters Laboratories)

1.3 QUALITY ASSURANCE

- A. The equipment shall, as a minimum, be in strict compliance with the requirements of this specification and shall be the manufacturer's standard commercial product unless specified otherwise. Additional equipment features, details, accessories, appurtenances, etc. which are not specifically identified but which are a part of the manufacturer's standard commercial product, shall be included in the equipment being furnished.
- B. The equipment shall be of the type, design, and size that the manufacturer currently offered for sale and appears in the manufacturer's current catalogue. The equipment shall be new and fabricated from new materials and shall be free from defects in materials and workmanship.
- C. The equipment must fit within the allocated space, leaving ample allowance for maintenance and cleaning, and must leave suitable space for easy removal of all equipment appurtenances.
- D. All units of the same classification shall be identical to the extent necessary to insure interchangeability of parts, assemblies, accessories, and spare parts wherever possible.
- E. In order to provide unit responsibility for the specified capacities, efficiencies, and performance, the boiler manufacturer shall certify in writing that the equipment being submitted shall perform as specified. The boiler manufacturer shall be responsible for guarantying that the boiler provides the performance as specified herein.

1.4 SUBMITTALS

- A. The contractor shall submit, in a timely manner, all submittals for approval by the engineer. Under no circumstances shall the contractor install any materials until the engineer has made final approval on the submittals.
- B. The engineer shall review and stamp submittals. Work may proceed and equipment released for fabrication after contractor receives returned submittals stamped with “NO EXCEPTIONS TAKEN” or “MAKE CORRECTIONS NOTED”.
- C. The bidder must submit in writing to the engineer any request for a proposed deviation, omission, modification, or substitution to this specification for evaluation no later than ten (10) days prior to the bid date. A request for any substitution shall be accompanied by technical data, drawings, product samples, and complete data substantiating compliance of proposed substitution with these specifications. No materials shall be deemed acceptable if not in strict and full compliance with these specifications. All bidders must bid solely on the specified materials unless acceptance by the engineer of a deviation, omission, modification, or substitution is granted in writing to all bidders prior to the bid date.
- D. Shop Drawings - Shop drawings shall be submitted to the engineer for approval and shall consist of:
 - 1. General assembly drawing of the boiler including product description, model number, dimensions, clearances, weights, service sizes, etc.
 - 2. Schematic flow diagram of gas valve trains.
 - 3. Schematic wiring diagram of boiler control system of the ladder-type showing all components, all interlocks, etc. Schematic wiring diagram shall clearly identify factory wiring and field wiring.
- E. Manufacturer’s Warranties: Manufacturer’s printed warranties, as specified hereinafter, shall be submitted prior to final acceptance by the engineer.
- F. Manufacturer’s Field Service: Manufacturer’s printed field service procedures and reports, as specified hereinafter, shall be submitted prior to final acceptance by the engineer. Report forms shall contain all information as required to do start-up and testing as specified in the products section.

1.5 CERTIFICATIONS

- A. Manufacturer’s Certification: The boiler manufacturer shall certify the following:
 - 1. The products and systems furnished are in compliance with the specifications, except as clarified in the bid package.
 - 2. The boiler and burner have all been properly coordinated and integrated to provide a complete and operable boiler.
 - 3. ASME certification.
 - 4. UL and CSD-1 (if applicable) certification.
 - 5. The equipment furnished has been installed in accordance with the manufacturer’s installation instructions.
 - 6. The specified factory tests have been satisfactorily performed.
 - 7. The specified field tests have been satisfactorily performed.
- B. Contractor’s Certification: The contractor shall certify the following:
 - 1. The products and systems installed are in strict compliance with the specifications.

2. The specified field tests have been satisfactorily performed.
- C. Boiler Inspectors' Certification: All boiler inspections during hydrostatic testing shall be performed by an authorized boiler inspector who is certified by the National Board of Boiler and Pressure Vessel Inspectors and shall be submitted in writing prior to final acceptance by the engineer.
- D. Test Reports: Factory and field test reports as described above and as specified hereinafter, shall be submitted prior to final acceptance by the engineer.
- E. Operation and Maintenance Manuals: Manufacturer's printed operation and maintenance manuals shall be submitted prior to final acceptance by the engineer. Operation and maintenance manuals shall contain, product data, operating instructions, cleaning procedures, replacement parts list, maintenance and repair data, etc.

1.6 SHIPMENT, STORAGE, AND HANDLING

- A. The contractor shall be responsible for the timely shipment of the equipment to the job site. The contractor shall be responsible for unloading and rigging of the equipment. The contractor shall be responsible for protecting the equipment from the weather, humidity and temperature conditions, dirt, dust, other contaminants, as well as job site conditions during construction.
- B. Equipment shall be unloaded, handled, and stored in accordance with the manufacturer's handling and storage instructions.
- C. The work to be performed consists of providing all labor, equipment, materials, etc. to furnish and new factory assembled, low pressure hot water boilers as described in the specifications herein.

PART 2 PRODUCTS

2.1 MANUFACTURERS

- A. Contractor shall furnish and install Cleaver Brooks Model 4WI _____ natural gas (combination Gas/Oil fired) hot water boiler(s) with design pressure as scheduled on the drawings.
- B. Alternate manufacturers complying with plans and specifications must be submitted and approved by the consulting engineer within 10 days prior to bid date.

2.2 GENERAL DESCRIPTION

- A. Factory packaged unit shall include boiler, burner, heavy duty skids, painted steel jacket with two inches of fiberglass insulation, controls and accessories all piped and wired for single point field connections. Units shall carry packaged label of Underwriters Laboratory (UL) and be in accordance with ASME, all codes required by the local governing authorities and as indicated on the design performance data sheet. A certified factory fire-test shall be provided on all fuels with data sheets furnished to Engineer and Owner. ASME certified, labeled, stamped and designed for _____ PSIG water in accordance with Section IV of ASME Code. Unit shall be designed to Seismic Zone requirements applicable to boiler location. Manufacturer's Representative to provide services for field testing and adjusting of boiler and controls to meet design requirements.

2.3 PERFORMANCE: BOILER SIZE AND RATINGS

- A. The capacity of each unit shall be indicated on the drawing schedule.
- B. Performance Criteria:

Performance Criteria	
Manufacturer:	CLEAVER-BROOKS
Model:	Promethean Line
Horsepower:	_____ HP
Output:	_____ #/hr (from and at 212°F)
Gas Input:	_____ MBH
Oil Input:	_____ GPH
Design Pressure:	_____ PSIG
Operating Pressure	_____ PSIG
Operating Temperature	_____ degrees F
Heating Surface (minimum):	_____ Sq. Ft. Fireside
Burner Turndown Ratio Natural Gas:	
Overall Efficiency	
Natural Gas (%):	_____ % at High Fire
No. 2 Oil (%):	_____ % at High Fire
NOX Emission (maximum)	
Gas (Natural):	_____ PPM (corrected to 3%O ₂)
Oil (No. 2):	_____ PPM (corrected to 3%O ₂)
CO Emissions (maximum)	
Gas (Natural):	_____ PPM (corrected to 3%O ₂)
Oil (No. 2):	_____ PPM (corrected to 3%O ₂)
Electrical:	_____ V / _____ H / _____ P
Fan Motor:	_____ HP
Air Compressor Motor:	_____ HP
Oil Pump Motor:	_____ HP
Noise Level (3' from burner):	_____ dBA
Available Gas Supply Pressure:	_____ PSIG
Weight	
Dry:	_____
Flooded:	_____
Seismic Zone:	_____
Altitude:	_____ ASL
Code Requirements:	ASME / NATIONAL BOARD CSD-1 NFPA 85 (optional) Underwriter's Lab (UL) State Of _____ Factory Mutual (FM) (optional) GE-GAP (optional)

- C. Noise Sound Levels: Based on ABMA test code for packaged boilers measured 4-1/2 feet vertically above the bottom of the base rail and 3'0" horizontally in front of the end of the blower motor or front surface of control cabinet. Sound levels dBA on the scale in reference to 0.0002 microbars.

High Fire	#2 oil	dBA
Low Fire	#2 oil	dBA
High Fire	Nat Gas	dBA
Low Fire	Nat Gas	dBA

2.4 EFFICIENCY GUARANTEE

The boiler manufacturer shall guarantee that, at the time of startup, the boiler will achieve _____ fuel-to-steam efficiency at 100% firing rate when burning natural gas and _____ fuel-to-steam efficiency at 100% firing rate when burning oil (add efficiency guarantees at 25%, 50%, and 75% of rating, if required). If the boiler(s) fail to achieve the corresponding guaranteed efficiency as published, the boiler manufacturer will rebate, to the ultimate boiler owner, ten thousand dollars (\$10,000) for every full efficiency point (1.0%) that the actual efficiency is below the guaranteed level.

The specified boiler efficiency is based on the following conditions.

Natural Gas

- Carbon, % (wt) = 69.98
- Hydrogen, % (wt) = 22.31
- Sulfur, % (wt) = 0.0
- Heating value, Btu/lb. = 21,830

No. 2 Oil

- Carbon, % (wt) = 85.8
- Hydrogen, % (wt) = 12.7
- Sulfur, % (wt) = 0.2
- Heating value, Btu/lb. = 19,420

No. 6 Oil

- Carbon, % (wt) = 86.6
- Hydrogen, % (wt) = 10.9
- Sulfur, % (wt) = 2.09
- Heating value, Btu/lb. = 18,830

Efficiencies are based on ambient air temperature of 80 °F, relative humidity of 30%, and 15% excess air in the exhaust flue gas.

Efficiencies are based on manufacturer's published radiation and convection losses. (For Cleaver-Brooks radiation and convection losses, see Boiler Efficiency Facts Guide, publication number CB-7767).

Any efficiency verification testing will be based on the stack loss method.



Warranty

All equipment is to be guaranteed against defects in materials and/or workmanship for a period of 12 months from date of start-up or 18 months from date of shipment, whichever comes first.

Shop Tests

The packaged boiler must receive factory tests to check the construction, controls, and operation of the unit. All tests may be witnessed by the purchaser, if desired.

Start-up Service

After boiler installation is completed, the manufacturer shall provide the services of a field representative for starting the unit and training the operator at no additional costs.

A factory approved and authorized start-up report shall be submitted to the customer/user at the time of start-up.

2.5 GENERAL BOILER DESIGN

- A. The boiler shall be a four pass horizontal firetube updraft boiler with five (5) square feet (except 750 or 800 hp) of heating surface per rated boiler horsepower. It shall be mounted on a heavy steel frame with integral forced draft burner and burner controls.
- B. The complete package boiler shall be approved as a unit by Underwriters Laboratories and shall bear the UL/ULC label, except in the case where 50 Hz has been selected.
- C. The boiler shall be completely pre assembled and fire tested at the factory. The unit shall be ready for immediate mounting on floor or simple foundation and ready for attachment of water, steam, fuel, electrical, vent and blowdown connections.
- D. The boiler shall be built to comply with the following insurance and codes _____ (Factory Mutual, ASME CSD-1).

2.6 BOILER SHELL (HOT WATER)

- A. The boiler shell must be constructed in accordance with ASME Boiler Code and must receive authorized boiler inspection prior to shipment. A copy of the inspection report shall be furnished to the purchaser.
- B. The hot water return and outlet connections shall be located on the top center line of the boiler. The boiler shall be designated to rapidly mix the return water with the boiler water. Forced internal circulation shall be used.
- C. A dip tube shall be included as an integral part of the water outlet.
- D. Two lifting eyes shall be located on top of the boiler.
- E. Front and rear doors on the boiler shall be hinged or davited. Doors are to be sealed with fiberglass tadpole gaskets and fastened tightly using heavy capscrews that thread into replaceable brass nuts.
- F. Rear refractory and insulation shall be contained in the formed door, which must swing open for inspection of brick work.
- G. The boiler tubes shall not include turbulators, swirlers or other add-on appurtenances.
- H. Front and rear tube sheets and all flues must be fully accessible for inspection and cleaning when the doors are swung open. The shell must be furnished with adequate handholes to facilitate boiler inspection and cleaning.
- I. The exhaust gas vent shall be located near the front of the boiler on the top center line and shall be capable of supporting 1000 lbs and shall contain a stack thermometer.

2.7 EMISSION CONTROLS

- A. Boiler shall be equipped with a low emission (LE) option for guaranteed NO_x performance at _____ ppm, dry volume basis and corrected to 3% O₂ when firing natural gas.
- B. The low emission option shall include an integral front head, burner, and boiler package, providing NO_x reduction through an internal flue gas recirculation system using the combustion air fan, internal recirculation valve, and enhanced boiler design to achieve the guaranteed NO_x levels. The emission control system shall not use an external fan, control valve, and piping. Boiler fuel-to-steam efficiency and rated boiler capacity shall be guaranteed while the boiler is operating at the low NO_x performance levels.
- C. Burner, boiler, and low NO_x system shall be manufactured as a package by a single manufacturer. The Low Emission Option to the CB Boiler shall include factory testing as a package, and shall bear the UL packaged label. The boiler nameplate shall include the approved UL low NO_x boiler model designation. No field assembly of the burner or low NO_x equipment shall be required.

2.8 HOT WATER BOILER TRIM

- A. Low Water Cutoff
A low water cutoff control (manual reset) shall be mounted on the top centerline of the boiler wired into the burner control circuit to prevent burner operation if boiler water falls below a safe level.
- B. Pressure and Temperature Gauges
Pressure and temperature gauges shall be mounted on the boiler with temperature sensing element located adjacent to the hot water outlet.
- C. Relief Valves
Water relief valves of a type and size to comply with ASME Code requirements shall be shipped loose.
- D. Temperature Controls
Temperature controls to regulate burner operation shall be mounted on the unit with temperature sensing elements located adjacent to the hot water outlet. Controls shall be high limit (manual reset), operating limit (auto reset), and firing rate control (30-100 hp).

2.9 BURNER AND CONTROLS

- A. Mode of Operation
- B. Burner operation shall be full modulation principle. The burner shall always return to low fire position for ignition.

2.10 BLOWER

- A. Air for combustion shall be supplied by a forced draft blower mounted in the front boiler door, above the burner, to eliminate vibration and reduce noise level.
- B. Maximum sound level of the boiler/burner package shall not exceed _____ dbA (when measured in accordance with ABMA Sound Test Standards).
- C. The impeller shall be cast aluminum, radial blade, carefully balanced, and directly connected to the blower motor shaft.

2.11 COMBUSTION AIR CONTROL

Combustion air damper and cam operated fuel metering valves shall be operated by a single damper control motor that regulates the fire according to load demand. Potentiometer type position controls shall be provided to regulate operation of the damper control motor (remove this sentence when CB-HAWK flame safeguard is used).

2.12 FUEL SPECIFICATION AND PIPING

Select one of the following fuel types:

1. Fuel series 700 - Gas fired (4.4.1).
2. Fuel series 100 - Light oil (No. 2) fired (4.4.2).
3. Fuel series 200 - Light oil or gas fired (4.4.3).
4. Fuel Series 700 - Gas Fired

2.13 BURNER TYPE

The burner shall be integral with the front head of the boiler and of high radiant multi-port type for gas. The burner shall be approved for operation on natural gas fuel and equipped with an LE option.

2.14 GAS PILOT

The gas pilot shall be a premix type with automatic electric ignition. An electronic detector shall monitor the pilot so that the primary gas valve cannot open until pilot flame has been established. The pilot train shall include two manual shut-off valves, solenoid valve, pressure regulator and pressure gauge.

2.15 GAS BURNER PIPING

- A. Gas burner piping on all units shall include pressure regulating gas shutoff valve, motor operated with proof of closure switch and plugged leakage test connection. The main gas valve(s) shall be wired to close automatically in the event of power failure, flame failure, low water or any safety shutdown condition. A lubricating plug cock or butterfly shutoff valve shall be provided as a means for a tightness check of the primary shut off valve. An additional plug cock on butterfly valve shall be furnished at entrance to gas train. Select one of the following:
- B. 125-300 hp. High and low gas pressure switches shall be provided. A second motorized safety shutoff valve, plus an additional plugged leakage test connection shall be provided.
- C. 350-800 hp. High and low gas pressure switches shall be provided. A second motorized safety shutoff valve, plus an additional plugged leakage test connection shall be provided. A valve proving switch shall be located between the safety shutoff valves.

2.16 BURNER TURNDOWN

Select one of the following:

1. 125-200 hp. Turndown range of burner shall be 4:1 when firing natural gas.
2. 250-800 hp. Turndown range of the burner shall be 10:1 when firing natural gas with a 60 or 30 ppm LE option. (Consult with Cleaver-Brooks Representative regarding high turndown capability based on available gas pressure and 15 and 9 ppm LE options.)

2.17 FUEL SERIES 100

Light Oil Fired

2.18 BURNER TYPE

The burner shall be integral with the front head of the boiler, and shall be a low pressure air atomizing type approved for operation with CS12-48, Commercial No. 2 oil and equipped with an LE option.

2.19 GAS PILOT

The gas pilot shall be a premix type with automatic electric ignition. An electronic detector shall monitor the pilot so that the primary gas valve cannot open until pilot flame has been established. The pilot train shall include two manual shut-off valves, solenoid valve, pressure regulator and pressure gauge.

2.20 OIL PUMP

An oil pump with a capacity of approximately twice the maximum burning rate shall be included. Separate motor driven pump set, shipped loose to be installed in a location favorable to the oil storage tank, shall be provided.

2.21 OIL BURNER PIPING

Fuel oil piping on the unit shall include oil pressure regulating devices, oil metering controls, solenoid shutoff valves, pressure gauges and fuel strainer, all integrally mounted on the unit. A fuel oil controller shall be provided to combine all of the fuel oil controls into a single casting which is mounted on the front door of the unit. A single tip retractable nozzle shall be used for the low pressure air atomizing burner. A low oil pressure switch shall be included in the oil piping.

2.22 LOW PRESSURE AIR ATOMIZING

Separate air compressor module mounted on boiler base rail with low atomizing air pressure switch.

2.23 BURNER TURNDOWN Fuel Series 200 Light Oil or Gas Fired

125 hp through 200 hp. Turndown range shall be 4:1 when firing No. 2 oil. When Firing natural gas refer to section 2.23

2.24 BURNER TYPE

The burner, integral with the front head of the boiler, shall be a combination of the low pressure air atomizing type for oil and high radiant multi-port type for gas. The burner shall be approved for operation with either CS12-48 Commercial No. 2 Oil or natural gas. The burner shall be equipped with an LE option.

2.25 GAS PILOT

The gas pilot shall be premix type with automatic electric ignition. An electronic detector shall monitor the pilot so that the primary fuel valve cannot open until flame has been established. The pilot train shall include two manual shut-off valves, solenoid valve, pressure regulator and pressure gauge.

2.26 OIL BURNER

Oil Pump - An oil pump with a capacity of approximately twice the maximum burning rate shall be included. Separate motor driven pump set, shipped loose, to be installed in a location favorable to the oil storage tank, shall be provided.

2.27 OIL BURNER PIPING

Fuel oil piping on the unit shall include oil pressure regulating devices, oil metering controls, solenoid shutoff valves, pressure gauges and fuel strainer, all integrally mounted on the unit. A fuel oil controller shall be provided to combine all of the fuel oil controls into a single casting which is mounted on the front door of the unit. A single tip retractable nozzle shall be used for the low pressure air atomizing burner. A low oil pressure switch shall be included in the oil piping.

2.28 LOW PRESSURE AIR ATOMIZING

Separate air compressor module mounted on boiler base rail with low atomizing air pressure switch.

2.29 GAS BURNER PIPING

Gas burner piping on all units shall include pressure regulating gas shutoff valve, motor operated with proof of closure switch and plugged leakage test connection. The main gas valve(s) shall be wired to close automatically in the event of power failure, flame failure, low water or any safety shutdown condition. A lubricating plug cock or butterfly shutoff valve shall be provided as a means for a tightness check of the primary shut off valve. An additional plug cock or butterfly valve shall be furnished at entrance to gas train. Select one of the following:

2.30 BURNER

- A. Boiler Flame Safeguard Controller and Control Panel
- B. CB780E Flame Safeguard
- C. Boilers with CB780E Control - Each boiler shall be factory equipped with flame safeguard controller providing technology and functions equal to the Cleaver-Brooks Model CB780.
- D. Controller shall be computerized solid state having sequence and flame-on lights and digital "first out" fault code indications of flame safeguard trip functions. It shall include dynamic self-check logic. The controller shall have a fixed operating sequence incapable of being manually altered. The sequence shall include start, pre-purge, pilot and main fuel ignition run and post-purge cycles.
- E. Controller shall be the non-recycle type for maximum safety that shall shutdown the burner and indicate as a minimum the following trip functions: pilot and main flame failure, high and low fire proving switch faults, running interlocks open, false flame signal and fuel valve open (when proof of closure switch is furnished).
- F. The controller shall have a run/test switch. It shall allow interruptions to sequence just after pre- purge, during pilot ignition trial and run cycles for adjustments to firing rate motor, damper linkages and pilot flame for minimum turndown tests.

2.31 CONTROL PANEL

- A. The control panel shall be mounted on the front door of the boiler in a location convenient to the operator. The hinged metal cabinet shall have NEMA 1A rating that includes a neoprene dust seal and a Yale cabinet key type lock.

The panel shall contain the boiler flame safeguard controller, blower motor starter, indicating lights and selector switches.
- B. The panel shall have a removable sub-base for mounting the flame safeguard controller, blower motor starter, and terminal blocks. For combination gas-oil fired boilers the panel shall contain the fuel selector switch.

- C. The panel shall contain the following lights and switches:
 - 1. Lights
 - 2. White - load demanded.
 - 3. White - fuel valve open.
 - 4. Red - low water.
 - 5. Red - flame failure.
 - 6. Control Switches
 - 7. Burner On-Off.
 - 8. Manual-Automatic.
 - 9. Manual Firing Rate Control.
- D. Oil, heat and moisture resistant wire shall be used and identified with circuit numbers corresponding to the electrical wiring diagram.
- E. All electrical equipment and wiring shall be in conformance with Underwriters Laboratories requirements.
- F. Boiler to be supplied with a control circuit transformer and fuse protection for the control circuit.

2.32 BOILER CONTROLS

- A. **BOILER MANAGEMENT CONTROL SYSTEM CONTROL PANEL:** Boiler mounted NEMA 1 enclosure(s) with key lock; fusing, magnetic starters; step-down control transformer; flame safeguard and burner management system as indicated; annunciator lights for load demand, fuel on, low water and flame failure; selector switches, required by dry contacts, relays and terminal strips. Oil, heat and moisture resistant wire with circuit number corresponding to electrical wiring diagrams. In accordance with UL and National Electric Code.
- B. **(OPTION 1) BURNER MANAGEMENT SYSTEM (CB 780E Standard):** Boiler mounted in control panel enclosure. Microprocessor-based control to monitor all critical boiler and burner interlocks control and supervise burner light off sequence, and initiate an orderly safety procedure in the event of interlock or flame failure. Dynamic self checking. System to provide pre-post purge status, fault history, and diagnostic information by means of a two-line alpha-numeric display with alarm/status LEDs.
- C. **(OPTION 2) CB-HAWK ICS Boiler Control System (Optional upgrade):** Integrated Boiler Control And Management System
Boiler shall be factory equipped with a Boiler Control System combining a Digital Burner Management System for flame safety, and a Programmable Logic Controller for boiler modulation and operator interface functions.

The factory pre-configured Boiler Control System shall integrate the Burner Management functions and the PLC based modulation and operator interface functions. The logic of the Burner Management System and the modulating controls will not be run in the same processor or powered by the same DC supply. The PLC and Operator Interface Hardware shall be as manufactured by Allen Bradley.

Major system components shall include:
 - a. Programmable Logic Controller
 - b. Touch Screen HMI

- c. One Burner Management Controller with Wiring Sub-Base
- d. One Flame Scanner and amplifier
- e. Various Temperature and Pressure Sensors

Major functions provided by the Boiler Control System shall be:

Automatic sequencing of the boiler through standby, pre-purge, pilot flame establishing period, main flame establishing period, run, flame proving and lockout and post-purge

1. Full modulating control of fuel and air
2. Utilize solid state controls and sensors to provide various control functions, such as:
 - a. Modulating control (algorithm shall be Proportional-Integral-Derivative (PID) type)
 - b. Thermal shock protection
 - c. High and Low limit alarms and shutdowns
3. Touch Screen graphical operator interface and monitoring
 - a. Manual control of the boiler firing rate using control screens on the HMI to increment or decrement the firing rate
 - b. On screen indication of burner management controller status and diagnostics
 - c. On screen display of system alarms and faults
 - d. On screen history of alarms and faults
 - e. On screen recommendations for troubleshooting of fault conditions
 - f. On screen water level indication and alarm(s)
 - g. Stack Flue Gas, Combustion Air and Shell (water) temperature indication
4. Boiler efficiency calculation
5. Low Fire Hold with Minimum Temperature Control
6. Assured Low Fire Cut-Off (ALFCO)
7. The Boiler Control System shall incorporate the following safety provisions:
 - a. Examine all load terminals to assure it is capable of recognizing the true status of the external controls, limits and interlocks. If any input fails this test, the Burner Management System shall lockout on safety shutdown.
 - b. Closed-loop logic test of critical loads (ignition, pilot and main fuel valves) and must be able to lockout on safety.
 - c. Pre-ignition interlocks (fuel valve proof of closure, etc.) and flame signal checked during Standby and Pre-Purge.
 - d. Dynamic checking of the flame signal amplifier.
 - e. Safe start check and expand check to include monitoring flame signal during standby.
 - f. High and Low fire switches checked for proper sequencing.

The Boiler Control System shall provide the ability to communicate with external digital devices via Ethernet as a standard. It shall be possible to communicate with any OPC compliant device. Internet communications shall be supported, with the Boiler Control System supplied with its own IP address.

2.33 ACCESSORIES - BOILER FLUE VENT**2.34 MANUFACTURER FIELD SERVICES**

- A. General: The boiler and accessories supplier shall be responsible for performance of inspections, start up and testing of the package boiler and accessory equipment and materials furnished under this Section. A detailed written record of the start up performance, including burner setting data over the entire load range shall be furnished to the test engineer before test personnel leave the site. All labor, equipment and test apparatus shall be furnished by the supplier. All equipment defects discovered by the tests shall be rectified. The minimum time for two (2) boilers is five (5) days.
- B. Equipment inspection: Boiler representative to provide _____ hours of jobsite assistance to inspect boilers and other equipment upon arrival, verifying completeness of equipment supplied and potential damages. Responsibility of making freight claims to be performed by contractor or owner personnel.
- C. Pre start-up walk through: Boiler representative shall spend _____ hours at jobsite reviewing installation with mechanical contractor to be conducted approximately 1 week prior to startup.
- D. Start-up shall be conducted by experienced and factory authorized technician in the regular employment of the boiler supplier, and shall include:
1. Demonstrate that boiler, burner, controls and accessories comply with requirements of this Section as proposed by the boiler and accessories supplier. Pre-test all items prior to scheduling the final testing that will be witnessed by the test engineer.
 2. Readings at different firing rates (25, 50, 75 and 100%) of load for the modulating burner shall be taken with a written report of the tests submitted to the test engineer. The reports shall include readings for each firing rate tested and include stack temperatures, O₂, CO, NO_x, and overall boiler efficiency.
 3. Auxiliary Equipment and Accessories: Observe and check all valves, draft fans, electric motors and other accessories and appurtenant equipment during the operational and capacity tests for leakage, malfunctioning, defects, non compliance with referenced standards or overloading as applicable.
 4. Commissioning Requirements:
 - a. Fireside inspection
 - b. Waterside inspection
 - c. Closing and resealing of doors, manways and hand holes
 - d. Set up fuel train and combustion air system
 - e. Set up operating set points
 - f. Check all safeties, including: Flame safeguard, LWCO, ALWCO, Air flow, Fuel pressures, High limits
 - g. Set up and verify efficiencies at 25%, 50%, 75%, and 100%
 - h. Set up and verify burner turndown.
 - i. Set up and verify feedwater/level controls
- E. Training to include all safety procedures, maintenance procedures, control operations, and diagnostic procedures. Training to be provided in a single _____ hour continuous session to accommodate operator's availability on site.

2.35 OPERATING & MAINTENANCE MANUALS

- A. Provide two (2) Operating and Maintenance manuals including cut-away views of boiler and burner, schematics including fuel trains, general instructions for maintenance and inspections, complete spare parts lists and trouble shooting procedures.
- B. A wiring diagram corresponding to the boiler shall be affixed to the boiler near the electrical panel.

2.36 WARRANTY DATA

The entire boiler/burner package shall be guaranteed and warranted by the boiler manufacturer. Warranty shall include all parts for a period of (12) months from the date of start-up or beneficial use or 18 months from shipment, whichever comes first.

PART 3 EXECUTION**3.1 GENERAL**

Installation shall be provided by the contractor in accordance with the requirements of the codes specified hereinbefore. All of the contractor's work shall be performed by experienced workman previously engaged in boiler plant construction and shall be under the supervision of a qualified installation supervisor.

3.2 INSTALLATION

- A. Install equipment in strict compliance with state and local codes and applicable NFPA standards.
- B. Install components that were removed from equipment for shipping purposes.
- C. Install components that were furnished loose with equipment for field installation.
- D. Provide all interconnecting electrical control and power wiring.
- E. Provide all fuel gas vent and service piping.
- F. Provide all piping for boiler pipe connections.

3.3 FIELD TESTING

- A. The manufacturer's representative shall test all boiler and burner interlocks, actuators, valves, controllers, gauges, thermometers, pilot lights, switches, etc. Any malfunctioning component shall be replaced.
- B. All adjustments to boiler, burner, and boiler control system shall be performed by the manufacturer's representative.

3.4 START-UP, INSTRUCTION AND WARRANTY SERVICE

The manufacturer's representative shall provide start-up and instruction of each new boiler, including burner and boiler control system as specified herein. Start-up and instruction shall cover all components assembled and furnished by the manufacturer whether or not of his own manufacture.